



# Georgia FFA Association

## Lawnmower Operations CDE

### Middle School Division

---

#### I. OVERVIEW

The Middle School Lawn Mower and Equipment Operations & Maintenance Contest is an individual event, with three parts.

1. The contestant will answer questions on a written exam dealing with lawn mower and equipment operations, maintenance, and safety.
2. The contestant will have to determine the problem and the best solution to the problem in ten problem solving questions.
3. The contestant will have a practical driving test where he/she will exhibit his/her skills in driving a lawnmower through a designed course.

#### II. PURPOSE

The Middle School Lawn Mower and Equipment Operations & Maintenance Contest is designed to develop skills in operating lawnmowers and various pieces of equipment safely, as well as maintaining the mower in a safe and productive matter.

#### III. ELIGIBILITY

This event is open to students in grades 6-8 who are agricultural education students and are paid members of a chartered FFA chapter. Each student's name must appear on the chapter's FFA roster at least 10 days prior to competition above the chapter level.

*Chapters are limited to one (1) CDE contestant per chapter.*

#### IV. SPECIAL NEEDS REQUEST

To report any special needs or request special services for a student to compete in a Career Development Event or FFA Award area (Area or State level), it is the responsibility of the FFA advisor to provide a detailed and specific request and explanation in writing. Requests should include written documentation from the school system verifying the IEP and need being requested. Written requests must be submitted to the CDE Superintendent prior to registering for the CDE/event (at least 3 weeks prior to the date of competition).

#### V. RULES

The following rules will govern the driving:

1. Time begins when the mower crosses the start/finish line.
2. Time ends when the mower crosses the start/finish line.
3. No one will be allowed in the career development event area except the contestant and officials.
4. Safety violations will be noted by the judges. Three safety violations will disqualify the contestant at the discretion of the judges. **Safety is recognized as of the utmost importance.**
5. Course layout will be printed in the bulletin.
6. A lawnmower of a like model will be available for practice and acclimation

#### VI. EVENT FORMAT

The CDE will consist of three parts:

**Part I – Written Exam – 20 Points.** Contestants will *have 30 minutes to* answer **twenty** multiple-choice questions on lawnmower servicing, safe operation, care, and maintenance.



# Georgia FFA Association

## Lawnmower Operations CDE

### Middle School Division

---

**Part II – Problem Solving – 20 Points.** Contestants will *have 30 minutes to* answer **ten** multiple-choice problem solving activities relating to lawnmower servicing, safe operation, care and maintenance.

**Part III – Lawnmower Maintenance/Driving – 60 Points.** Contestants will be asked to name the listed **Daily Maintenance/Safety Checks** listed on the score sheet before Operating Mower. *Contestants will have a maximum of 2 1/2 minutes to navigate the course without penalty. Time will be stopped after six (6) minutes and the contestant will be scored (0) for incomplete.*

**The following lawnmower operations will be graded:**

- a. Explaining pre-warm up procedure. (**Daily Maintenance/Safety Checks**).
- b. Checking mowing height (height to be determined by the judge).
- c. Pulling out of the **Lawnmower Shed** which is represented by lines of stakes, not more than **(2') two feet** apart with **(6") six-inch clearance** on each side of the widest point of the mower deck **including Discharge Chute Assembly...**
- d. Driving the mower through a set **Alley** lined with stakes not more than **(2') two feet** apart with **(6") six inch clearance** on each side of the widest point of the mower deck **including Discharge Chute Assembly**, or the diagonal width of the mower determined by the diagonal width measured from the center of the inside front wheel to the outside center of the opposite rear wheel +18 inches, whichever is the largest measurement. Two five gallon buckets, two barrels, or two automobile tires will be placed in the course so that the contestant will have to circle each, as if they were mowing around trees. These objects will be set apart determined by the diagonal width, or the mower deck width including the discharge whichever is larger. Markers from the buckets, barrels, or tires will be set at the same width apart. The mower will then be driven to the course access lane and through in order to **back** the mower into the lawnmower shed **behind the start finish line**.

**\*\* For safety of participant and bystanders, the blade will not be engaged at any time during the driving portion of the event! Engaging the blade will result in Safety Penalty Points.**

## VII. SCORING

**Part I – Written Exam – 20 Points** (Each correct answer counting 1 point).

**Part II – Problem Solving – 20 Points** (Each correct answer counting 2 points).

**Part III – Lawnmower Driving – 60 Points** (Refer to the driving score card that is attached).



# Georgia FFA Association

## Lawnmower Operations CDE

### Middle School Division

---

#### \*Pre-Warm Up:

1. Failure to check:
  - a. Engine oil level \_\_\_\_\_ 40 points
  - b. Air filter \_\_\_\_\_ 30 points
  - c. Engine cooling system \_\_\_\_\_ 30 points
  - d. Cutting Blades \_\_\_\_\_ 30 points
  - e. Air Pressure in tires \_\_\_\_\_ 20 points
  - f. Fuel level \_\_\_\_\_ 10 points
  - g. Wheel lugs \_\_\_\_\_ 10 points
  - h. Battery Condition \_\_\_\_\_ 10 points
  - i. Belt tension and wear \_\_\_\_\_ 10 points
  - j. Brake Lock \_\_\_\_\_ 5 points
  - k. Discharge Chute Assembly \_\_\_\_\_ 5 points
  - l. Safety Starting Switches \_\_\_\_\_ 5 points
  - m. Belt Shields \_\_\_\_\_ 5 points

**Safety Equipment** (Brake lock, Discharge Chute Assembly, Safety Starting Switches- (Seat, PTO, Backup), Belt Shields

2. Driving Lawnmower
  - a. Efficient completion of skill – One point deducted for each second over 150 seconds (2 1/2 minutes).
  - b. Attempting to crank the lawnmower with safety switch engaged–number of times X 10
  - c. Stalling engine- number of times X 10
  - d. Excessive engine speed (RPM's) X 10
  - e. Pull-ups and back-ups to improve position – number of times X 10.
  - f. Markers scraped – number of times X 20.
  - g. Markers moved or upset – number of times X 40.
  - h. Failure to select suggested **deck height**- number of times X 10.
  - i. Failure to raise mower deck before entering shed x 10
  - j. Improper use of clutch- number of times X 10.
  - k. Operating mower in improper direction- number of times X 20.
  - l. Number of inches lawnmower wheels off center in Lawnmower Shed – number of times X 20.
3. Safety measures when driving lawnmower
  - a. Excess speed when turning and driving – number of times X 40.
  - b. Mounting/Dismounting lawnmower improperly - number of times X 20.
  - c. Failure to kill or shut engine off when dismounting- number of times X 100.
  - d. Failure to applying parking brake when dismounting- number of times X 100.
  - e. Releasing brake before starting- number of times X 20.
  - f. Mower Deck (Blades) Engaged – number of times X 100.
  - g. Failure to use hearing protection – number of times X 20.
  - h. Failure to use eye protection – number of times X 20.



# Georgia FFA Association Lawnmower Operations CDE Middle School Division

## VIII. TIE BREAKERS

In the event of a tie in the overall CDE, the contestant with the highest driving score will be declared the winner. Second tie breaker will be the contestant with the highest problem solving score while third tie breaker will be the contestant with the highest written exam score.

## IX. AWARDS

Awards shall be determined each year by the **Agriculture Education Office**. First and Second Place Winners from each Area will be presented a plaque at the appropriate **Area award ceremony**.

## X. COURSE LAYOUT

### Lawnmower Operation & Maintenance-Middle School

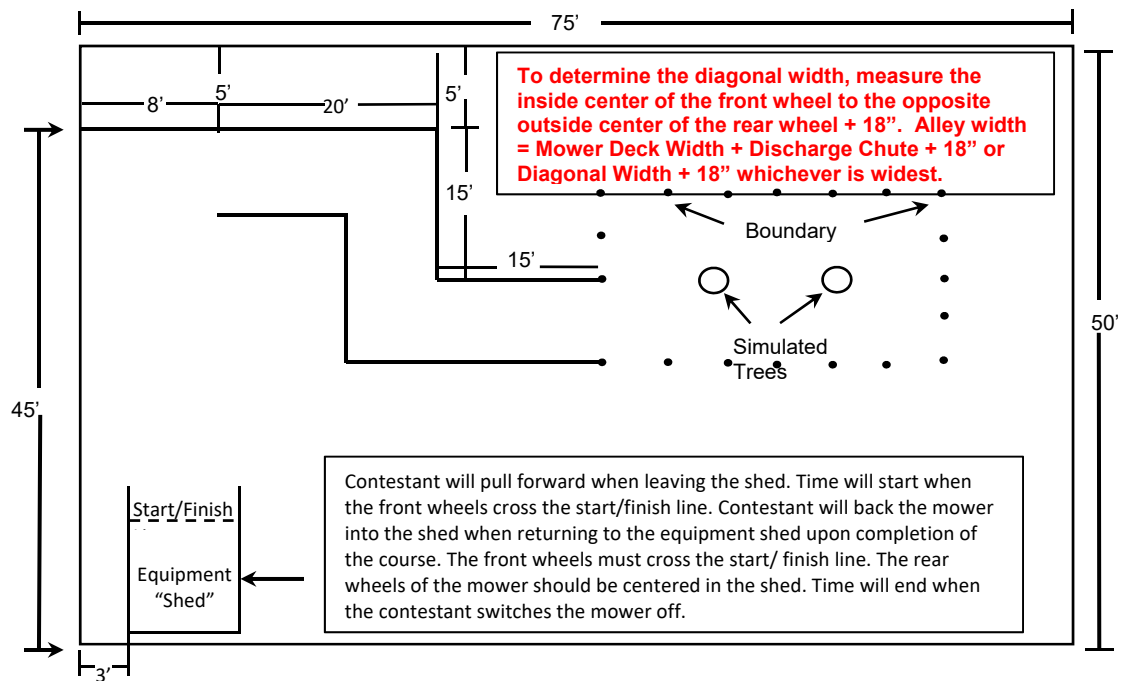





# Georgia FFA Association

## Lawnmower Operations CDE

### Middle School Division

---

## XII. References

### Texts

***Small Engines*** by R. Bruce Radcliff (Authorized by Briggs & Stratton), Current Edition, American Technical Publishers. ISBN 978-0-8269-0012-8 (Test and problem solving).

***Turfgrass Science and Management*** by Robert Emmons, Current Edition, Delmar Publishers.

[http://www.delmarlearning.com/Browse\\_CatalogDetail\\_Print.aspx?xxID=27423&isbn=1418013307](http://www.delmarlearning.com/Browse_CatalogDetail_Print.aspx?xxID=27423&isbn=1418013307) (Test and Problem Solving)

### **Lawnmower Operators Manuals** (the following list is only examples not intended to be comprehensive!)

<http://www.troybilt.com/wcsstore/pics/TroyBilt/769-03502.pdf>

<http://www.troybilt.com/wcsstore/pics/TroyBilt/769-03537.pdf>

<http://www.troybilt.com/wcsstore/pics/TroyBilt/769-03532.pdf>

<https://www.managemyhome.com/mmh/user-profile/CreateUserProfileDisplay.action?>

### **Sears Craftsman Manuals**

[http://www.usa.husqvarna.com/support\\_manual\\_search.aspx](http://www.usa.husqvarna.com/support_manual_search.aspx)

<http://www.snapper.com/manuals/#>

<http://www.exmark.com/Manuals.htm>

[http://www.usa.husqvarna.com/support\\_manual\\_search.aspx/landscapers.aspx](http://www.usa.husqvarna.com/support_manual_search.aspx/landscapers.aspx)

<http://www.snapper.com/manuals/#> Select Z Rider

[http://manuals.deere.com/cceomview/OMM157372\\_H7/Output/Index.html](http://manuals.deere.com/cceomview/OMM157372_H7/Output/Index.html)

<http://www.dixiechopper.com/support.php>

[http://manuals.deere.com/cceomview/OMM157372\\_H7/Output/Index.html](http://manuals.deere.com/cceomview/OMM157372_H7/Output/Index.html)

### **Lawnmower Engine Manufacturers Service and Repair Manuals**

## XIII. CDE Course Dimensions - Based on Region Mower sizes

Alley width and distance between simulated trees = 74 inches



# Georgia FFA Association Lawnmower Operations CDE Middle School Division

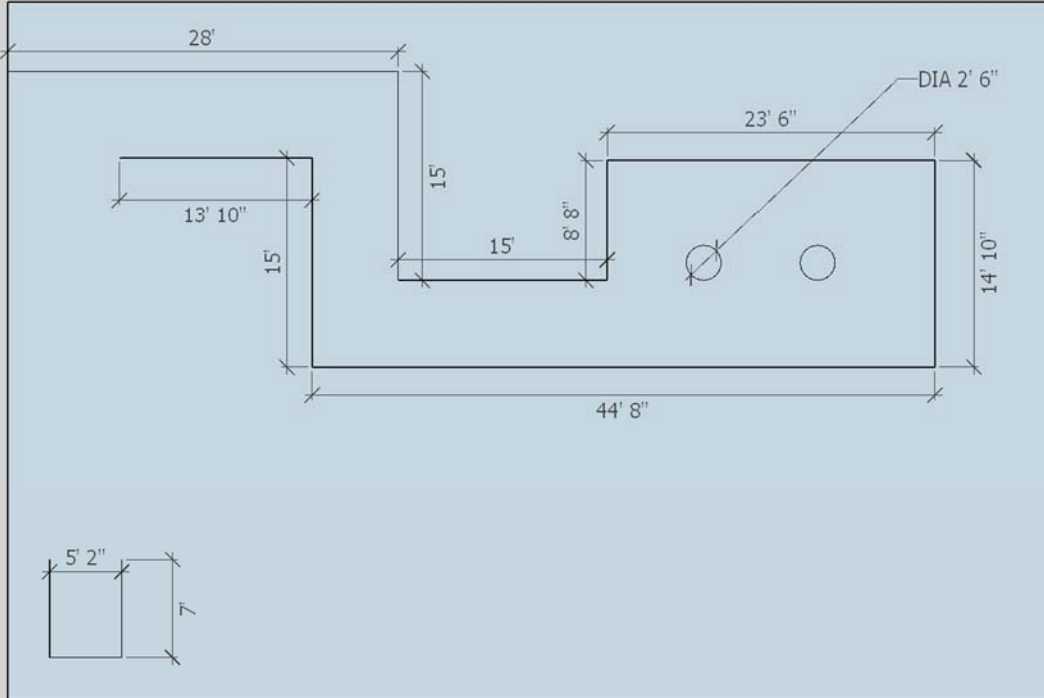



# Georgia FFA Association

## Lawnmower Operations CDE

### Middle School Division

---

CONTESTANT # \_\_\_\_\_ NAME \_\_\_\_\_ CHAPTER \_\_\_\_\_  
 TIME \_\_\_\_\_

PRE-WARM UP	NO. TIMES	TOTAL POINTS
Failure to Check:		
A. Engine oil level	X 40	
B. Air filter	X 30	
C. Engine Cooling System	X 30	
D. Cutting Blades	X 30	
E. Air Pressure in tires	X 20	
F. Fuel Level in Tank	X 10	
G. Wheel Lug tightness	X 10	
H. Battery Condition	X 10	
I. Belt Tension and Wear	X 10	
J. Brake Lock	X 5	
K. Discharge Chute Assembly	X 5	
L. Safety Starting Switches	X 5	
M. Belt Guards	X 5	
<b>DRIVING LAWNMOWER</b>		
1. Efficient completion of skill - No. seconds over 150	X 1	
2. Attempting to crank lawnmower with safety kill switch engaged	X 10	
3. Stalling Engine	X 10	
4. Excessive engine Speed (RPM's)	X 10	
5. Pull-ups & backups to improve position (No. times)	X 10	
6. Markers scraped (Number)	X 20	
7. Markers moved or upset (Number)	X 40	
8. Failure to select suggested deck height	X 10	
9. Failure to raise mower deck before entering shed	X 10	
9. Improper use of clutch (No. times)	X 10	
10. Operating mower in the improper direction	X 20	
11. Number of inches wheels off-center in <u>Lawnmower Shed</u>	X 10	
<b><u>SAFETY</u></b>		
1. Excess speed when turning & driving (No. times)	X 40	
2. Mounting /Dismounting lawnmower improperly (No. times)	X 20	
3. Failure to kill engine with key when dismounting (No. times)	X 100	
4. Locking brakes when dismounting (No. of failures)	X 100	
5. Unlocking brakes before starting (No. of failures)	X 20	
6. Mower Deck (Blades) Engaged	X 100	
7. Failure to use hearing protection	X 20	
8. Failure to use eye protection	X 20	

---

Lawnmower Operations CDE – Middle School Division (2018-2021)

Georgia FFA  
 Revised June 2018

**Total Penalty Points**  
 60 - NO. OF PENALTY POINTS X 60 = DRIVING SCORE  
 1000





# Georgia FFA Association Lawnmower Operations CDE Middle School Division

---

**GEORGIA FFA ASSOCIATION – CAREER DEVELOPMENT EVENT  
AUTHORIZATION, WAIVER & RELEASE OF LIABILITY  
TO BE SIGNED BY STUDENT AND GUARDIAN  
THIS DOCUMENT AFFECTS LEGAL RIGHTS – READ IT CAREFULLY**

\_\_\_\_\_  
Student (Please Print Name)

\_\_\_\_\_  
Career Development Event (CDE) (Please Print)

For purposes hereof, "Student" and "CDE" shall have the meaning set forth above.

**Please Check Section Applicable on Date of Signature**

\_\_\_\_\_  
**STUDENT UNDER AGE 18: I represent and warrant that I am the parent or legal guardian of the Student, who is under the age of eighteen (18) (the "Minor") as of the date hereof, and I, for myself and on the Minor's behalf, knowingly agree to the terms set forth herein.**

\_\_\_\_\_  
**STUDENT OVER AGE 18: I, the Student, represent and warrant I am over the age of eighteen (18) as of the date hereof, and I knowingly agree to the terms set forth herein.**

1. **Permitted Activities.** I acknowledge that Georgia FFA Association (the "**FFA**") only permits Student's participation in this CDE in a manner consistent with the rules established by the FFA for the CDE. (collectively, the "**Permitted Activities**"). I acknowledge and hereby agree that Student has read the rules, or is otherwise familiar with the rules, established by the FFA for the CDE, has had an opportunity to request clarification from appropriate advisors or officials regarding any rules that are unclear to the Student, and has received sufficient training to participate in the CDE in manner consistent with the rules established by the FFA for the CDE. It is agreed and understood that Student's participation in the CDE is voluntary.

2. **WAIVER AND RELEASE.** I HEREBY EXPRESSLY WAIVE AND RELEASE ANY AND ALL CLAIMS, KNOWN OR UNKNOWN, AGAINST THE FFA, THE OWNER OF ANY REAL PROPERTY OR PERSONAL PROPERTY USED FOR PURPOSES OR IN FURTHERANCE OF THE CDE, ANY PERSON PRESENT AT THE CDE, INCLUDING WITHOUT LIMITATION ADVISORS, ORGANIZERS, JUDGES, COORDINATORS, SPECTATORS, VOLUNTEERS, DONORS, AND CO-PARTICIPANTS, AND THEIR RESPECTIVE OFFICERS, DIRECTORS, EMPLOYEES, EMPLOYERS, AGENTS, AFFILIATES, SHAREHOLDERS, SUCCESSORS AND ASSIGNS (COLLECTIVELY, "**RELEASEES**"), RELATED TO BODILY INJURY TO OR DISABILITY OR DEATH OF THE STUDENT OR DAMAGE TO ANY OF THE STUDENT'S PROPERTY ARISING OUT OF THE STUDENT'S PARTICIPATION IN OR PRESENCE AT THE CDE.

3. **ASSUMPTION OF RISKS.** I HEREBY KNOWINGLY AND VOLUNTARILY ACCEPT AND ASSUME ANY AND ALL RISKS, FORESEEABLE OR UNFORESEEABLE, KNOWN OR UNKNOWN, OF INJURY TO OR DISABILITY OR DEATH OF THE STUDENT OR DAMAGE TO ANY OF THE STUDENT'S PROPERTY, WHETHER CAUSED BY THE NEGLIGENCE OR WRONGFUL CONDUCT OF THE FFA, THE STUDENT'S ADVISOR OR OTHER MENTOR OR COACH RELATED TO THE STUDENT'S INVOLVEMENT IN THE CDE, THE ORGANIZERS, COORDINATORS, OR JUDGES OF THE CDE, CO-PARTICIPANTS, SPECTATORS, VOLUNTEERS, OR THIRD PARTIES ATTENDING THE CDE, THE OWNER OF ANY REAL OR PERSONAL PROPERTY USED FOR THE CDE, AND THEIR RESPECTIVE EMPLOYEES, EMPLOYERS, AFFILIATES, OR AGENTS. I ACCEPT PERSONAL RESPONSIBILITY FOR ANY LIABILITY, INJURY, LOSS, OR DAMAGE IN ANY WAY CONNECTED WITH THE STUDENT'S PARTICIPATION IN THE CDE. I acknowledge that the Permitted Activities involve the risk of serious bodily injury, death, and/or property damage due to the inherent risks of the Permitted Activities, which could include but are not limited to: (a) possible equipment malfunction or misuse; (b) hazards related to traversing and driving across mostly undeveloped land, including without limitation holes, uneven dirt, fence

*Ver. August 2018*



# Georgia FFA Association Lawnmower Operations CDE Middle School Division

---

wire, and wild or poisonous animals or insects, (c) slipping or falling, including from elevated locations or while mounting or dismounting equipment; (d) colliding with motorized vehicles, persons, or stationary objects, (e) burns, cuts, and bruises, and (f) the Student's negligence or the negligence of other persons, including without limitation organizers, judges, and co-participants, related to the CDE. If the CDE involves interactions with animals, I understand the inherent risks of such animal activities also may include: (g) the propensity of animals to behave in ways that may result in injury, harm, or death; (h) the unpredictability of an animal's reaction to sounds, sudden movement, and unfamiliar objects, persons, or other animals; (i) collisions with other animals or objects; and (j) a Student's or third person's failure to maintain control over the animal.

4. Consent to Medical Treatment. I authorize FFA and the organizers of the CDE to provide to me, through medical personnel of their choice, customary medical assistance, transportation, and emergency medical services. This consent does not impose a duty upon FFA to provide such assistance, transportation, or services.

5. Publicity Release. I authorize FFA to use my name, photo, materials produced for the CDE or presentation in CDE for FFA materials including but not limited to, educational resources, press releases, web based publicity and other publicity materials.

6. Severability. Each term and provision of the instrument shall be valid and enforced separately to the fullest extent permitted by law. The unenforceability of any one term hereof shall not impact the enforceability of any other term.

7. Applicable Law. This instrument shall be governed, construed, and enforced in accordance with the law of the State of Georgia.

8. Additional Terms. This Authorization, Release, and Waiver shall be applicable for each occasion the Student participates in any CDE organized by the FFA and the terms hereof shall survive indefinitely; provided; however, FFA retains the right as a condition precedent to participating in any CDE to require Participant to deliver an additional Authorization, Waiver, and Release. A signed copy hereof received or maintained electronically shall have the same legal effect as an original.

**THIS IS A WAIVER AND RELEASE OF LIABILITY. I HAVE READ THIS AUTHORIZATION, WAIVER, AND RELEASE OF LIABILITY. I UNDERSTAND THAT I HAVE GIVEN UP SUBSTANTIAL RIGHTS BY SIGNING IT. I AM SIGNING THIS AUTHORIZATION, WAIVER, RELEASE OF LIABILITY VOLUNTARILY. I UNDERSTAND AND AGREE TO ALL OF THE TERMS OF THIS RELEASE.**

Student's Signature: \_\_\_\_\_ Date: \_\_\_\_\_

**IF THE STUDENT PARTICIPATING IN THE CDE IS NOT YET 18 YEARS OLD, BOTH PARENTS OR THE LEGAL GUARDIAN(S) MUST SIGN:**

In exchange for my/our child or ward being allowed to participate in the CDE, and as the parent(s) or legal guardian(s) of the above-named Student, I/we verify that I/we fully understand, agree to, and accept all provisions of this Authorization, Waiver, Release of Liability. I represent I have full authority to sign this Authorization, Waiver, Release of Liability on behalf of the Student. I knowingly and willingly grant the Minor (if applicable) permission to engage in the Permitted Activities.

Guardian:  
Printed Name \_\_\_\_\_ Signature \_\_\_\_\_ Date \_\_\_\_\_

Guardian:  
Printed Name \_\_\_\_\_ Signature \_\_\_\_\_ Date \_\_\_\_\_

Insurance Company: \_\_\_\_\_ Policy Number: \_\_\_\_\_

Guardian Contact Number: \_\_\_\_\_ Minor's Date of Birth: \_\_\_\_\_

*Ver. August 2018*