

LEVELING
AND

LAND
MEASUREMENT
PRACTICES

FOR
AGRICULTURE

A REFERENCE UNIT
IN
AGRICULTURAL MECHANIZATION
AGRICULTURAL EDUCATION DEPARTMENT
THE UNIVERSITY OF ARIZONA.

Reference Unit
on
LEVELING AND LAND MEASUREMENT
PRACTICES
for
AGRICULTURE

Clinton O. Jacobs

Keith E. Mattox

Department of Agricultural Education

University of Arizona

Tucson

February, 1974
Second Printing
February, 1978
Third Printing
September, 1984
Fourth Printing
July, 1986
Fifth Printing, August, 1990

FOREWORD

Surveying is the science of making the measurements necessary to determine the relative positions of points above, on or beneath the surface of the earth or to establish such points. For example, if the location of a geographic point is known, the position of an unknown point can be located and identified by reference to the known point.

Surveying is one of the oldest arts practiced by man, who from the earliest times found it necessary to mark boundaries and divide land. It is now indispensable in all branches of engineering. For example, surveys are required prior to and during the planning and construction of highways, railroads, buildings, bridges, missile ranges and launching sites, tunnels, canals, irrigation ditches, dams, drainage works, and water supply and sewage systems. They are also essential in laying out pipelines and mine shafts. The use of surveying or surveying methods has become common in the layout of assembly lines and jigs, the fabrication of airplanes, and the placement of equipment, and in many related tasks in aeronautical, agricultural, chemical, electrical, mechanical and mining engineering, and in geology.

Leveling, on the other hand, is the operation of determining the difference in elevation between points on the earth's surface. Agriculturalists have used leveling techniques for many years to assist them in leveling fields, acquiring desired slopes or grades, determining cuts and fills and other necessary farming operations.

Land measurement methods are used in agriculture to determine land acreage and distances. This form of survey originated in Egypt when ropes of determined lengths were used to measure plots of land. The Romans used ingenious measuring devices in construction of aqueducts and other work throughout the Empire. Today highly sophisticated electronic equipment is used for distance measurement.

The information and techniques of leveling and land measurement as described in this reference is applicable to a wide variety of agricultural operations. Students who develop the skill and accuracy to perform operations and tasks outlined in this reference will have attained the basic competencies needed to progress to more detailed instruction in leveling and measuring techniques.

ACKNOWLEDGEMENTS

The Reference Unit on Leveling and Land Measurement Practices for Agriculture has been developed through the cooperation of the staff, Department of Agricultural Education at the University of Arizona. Special acknowledgement is given to Mr. Allan D. Halderman, Extension Agriculture Engineer, Department of Soil and Water Engineering, University of Arizona, who reviewed the preliminary manuscript and provided invaluable expertise and practical insight.

Recognition is given to the Lietz Company, Surveyors Service Company, Keuffel & Essex Company, Realist, Inc., and C. L. Berger and Sons, Inc. for photographs and illustrations which were provided on request.

Line drawings and art work were prepared by Mr. Keith E. Mattox, Curriculum Specialist, Department of Agricultural Education.

TABLE OF CONTENTS

Unit	Page
Foreword	ii
Acknowledgements	iii
Table of Contents.	iv
I. LEGAL LAND DESCRIPTION	1
II. AGRICULTURAL LEVELING AND LAND MEASUREMENT EQUIPMENT.	11
Leveling Equipment	11
Land Measurement Equipment	20
Determining Land Acreage	29
III. USING LEVELING AND LAND MEASURING EQUIPMENT.	33
The Tripod Level	33
The Leveling Rod	39
Field Signals.	43
Leveling Terms and Field Notes	44
The Steel Tape	46
Measuring Horizontal Distances With a Level.	52
Land Measurement by Use of Aerial Maps	54
IV. LEVELING OPERATIONS.	57
Differential Leveling.	57
Profile Leveling	61
Contour Mapping.	64
Grades, Cuts, and Fills.	70
APPENDICES	
A. Laying a Foundation.	79
B. Field Note Page.	87
C. The Hand Level	91
D. Useful Numbers in Leveling	95
E. Staking Out a Fence.	99

UNIT I
LEGAL LAND DESCRIPTION

Introduction:

The oldest historical records in existence today, which bear directly on the subject of surveying and land measurement, state that this science had its beginning in Egypt. In about 1400 B.C., the land of Egypt was divided into plots for the purpose of taxation. When annual floods of the Nile River swept away portions of the plots, surveyors were appointed to reidentify land boundaries. These early surveyors were called "rope stretchers". Their measurements were made by means of ropes with markers at set distances. A later innovation of measuring land distance involved the marking of a wagon wheel with a cloth and counting of the revolutions it made as it traversed a distance across the land.

The earliest land surveys were made to locate or relocate boundary lines of property. Trees and other natural objects, or stakes driven into the ground, were used to identify specific locations. As property increased in value and owners disputed rights to land, the importance of permanent monuments and written records became evident. Property titles now are transferred by written documents called deeds, which contain a legal description of property boundaries.

There are three general sources from which the description of the boundaries of real property may be found: (1) deeds, (2) official plots or (3) notes of the original surveys.

Throughout the United States, records of the transfer of land from one person to another are kept either in the office of the city or town clerk or in the county registry of deeds. Exact copies of all deeds of transfer are filed in the deed books. These files are free to be examined by anyone and are frequently a source of information to the land surveyor in trying to establish a property boundary line.

The system of description used in the United States to identify the location of land holdings for legal purposes is based upon the Rectangular System of land survey. This system dates back to the Continental Congress of 1785 which passed a law to provide for the subdivision of public lands into townships, sections and quarter sections based upon the Rectangular System.

Rectangular System of Land Survey:

The layout of the Rectangular System was accomplished in the following manner. Townships were located with reference to a true north-south line called a principle meridian

and an east-west line of a true parallel of latitude called the base line. (Figure 1-1)

Where the principle meridian crosses the base line is known as the initial point.

The United States is divided into thirty-five regions for survey purposes. Each of these regions have an initial point serving as the origin for all public-land surveys. Arizona is a part of two of these regions and therefore has two initial points. The various initial points, base lines and principle meridians of the United States are designated by a name assigned to the principle meridian. The name of the principle meridians for Arizona are the "Gila and Salt River Meridian and Navajo Meridian". (Figure 1-2)

In this text we will be mostly concerned with the Gila and Salt River Meridian located near the city of Avondale. (Figure 1-3)

The next step in the subdivision of public lands is the placement of standard parallels and guide meridians.

Standard parallels of latitude are spaced at intervals of 24 miles north and south from the base line. The standard parallels are designated with respect to their relationship to the base line and become the First Standard Parallel North, Second Standard Parallel North, First Standard Parallel South, Second Standard Parallel South, and so on until the limits of the regions in Arizona have been covered. (Figure 1-4)

Guide meridians are spaced at intervals of 24 miles east and west of the principle meridian. The guide meridians become known as the First Guide Meridian East, First Guide Meridian West, Second Guide Meridian East, Second Guide Meridian West, and so on depending upon their locations with respect to the principle meridian. (Figure 1-5)

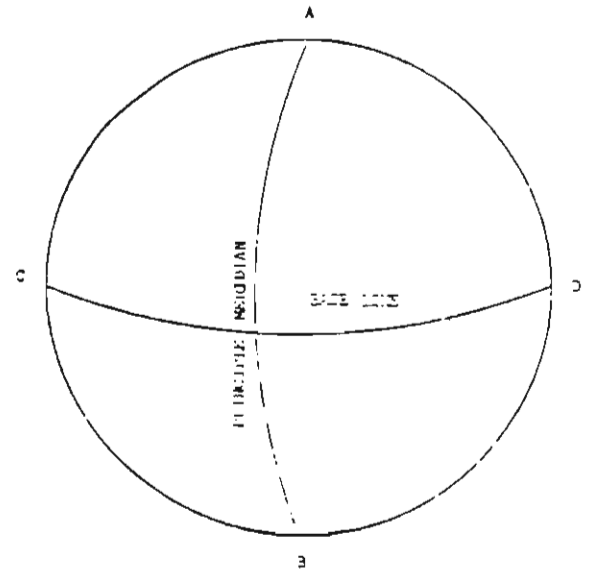

Fig. 1-1. This illustration of the earth shows the first step in the Rectangular System of land survey locating the Principle Meridian (AB) and the Base Line (CD).

and an east-west line of a true parallel of latitude called the base line. (Figure 1-1)

Where the principle meridian crosses the base line is known as the initial point.

The United States is divided into thirty-five regions for survey purposes. Each of these regions have an initial point serving as the origin for all public-land surveys. Arizona is a part of two of these regions and therefore has two initial points. The various initial points, base lines and principle meridians of the United States are designated by a name assigned to the principle meridian. The name of the principle meridians for Arizona are the "Gila and Salt River Meridian and Navajo Meridian". (Figure 1-2)

In this text we will be mostly concerned with the Gila and Salt River Meridian located near the city of Avondale. (Figure 1-3)

The next step in the subdivision of public lands is the placement of standard parallels and guide meridians.

Standard parallels of latitude are spaced at intervals of 24 miles north and south from the base line. The standard parallels are designated with respect to their relationship to the base line and become the First Standard Parallel North, Second Standard Parallel North, First Standard Parallel South, Second Standard Parallel South, and so on until the limits of the regions in Arizona have been covered. (Figure 1-4)

Guide meridians are spaced at intervals of 24 miles east and west of the principle meridian. The guide meridians become known as the First Guide Meridian East, First Guide Meridian West, Second Guide Meridian East, Second Guide Meridian West, and so on depending upon their locations with respect to the principle meridian. (Figure 1-5)

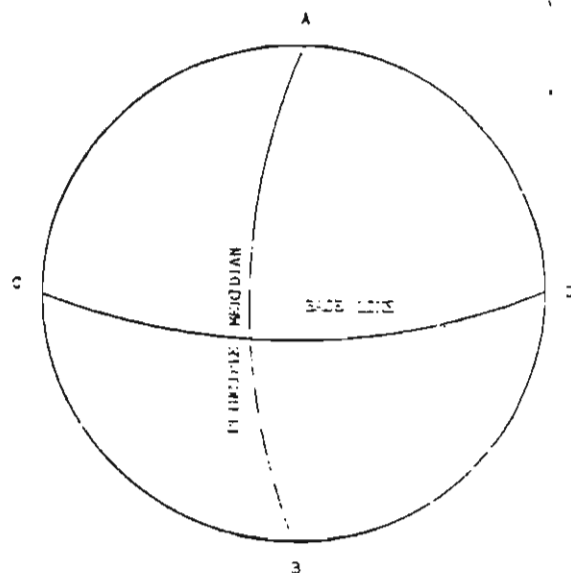

Fig. 1-1. This illustration of the earth shows the first step in the Rectangular System of land survey locating the Principle Meridian (AB) and the Base Line (CD).

Meridians	Governing surveys (wholly or in part) to States of--	Longitude of initial points west from Greenwich	Latitude of initial points
Black Hills.....	South Dakota.....	101 03 16	43 59 44
Boise.....	Idaho.....	116 23 35	43 22 21
Chickasaw.....	Mississippi.....	89 14 47	35 01 58
Choctaw.....	do.....	90 14 41	31 52 32
Cimarron.....	Oklahoma.....	103 00 07	36 30 05
Copper River.....	Alaska.....	145 18 13	61 49 21
Fairbanks.....	do.....	147 38 26	64 51 50
Fifth Principal.....	Arkansas, Iowa, Minnesota, Missouri, North Dakota, and South Dakota.	91 03 07	34 28 45
First Principal.....	Ohio and Indiana.....	84 46 11	40 59 22
Fourth Principal.....	Illinois ¹	90 27 11	40 00 50
Do.....	Minnesota and Wisconsin.....	90 25 37	42 30 27
Gila and Salt River.....	Arizona ¹	112 13 19	33 22 35
Humboldt.....	California.....	124 07 10	40 25 02
Huntsville.....	Alabama and Mississippi.....	86 34 16	34 59 27
Indian.....	Oklahoma.....	97 14 49	34 29 32
Louisiana.....	Louisiana.....	92 24 55	31 00 31
Michigan.....	Michigan and Ohio.....	84 21 53	42 25 28
Mount Diablo.....	California and Nevada.....	121 54 47	37 52 54
Nevada.....	Arizona.....	103 31 59	35 44 56
New Mexico Principal.....	Colorado and New Mexico.....	106 53 12	34 15 55
Principal.....	Montana.....	111 39 03	45 47 13
Salt Lake.....	Utah.....	111 53 27	40 46 11
San Bernardino.....	California.....	116 55 17	34 07 20
Second Principal.....	Illinois and Indiana.....	86 27 21	38 26 14
Seward.....	Alaska.....	149 21 24	60 07 36
Sixth Principal.....	Colorado, Kansas, Nebraska, South Dakota, and Wyoming.....	97 22 08	40 00 07
St. Helena.....	Louisiana.....	91 09 36	30 59 55
St. Stephens.....	Alabama and Mississippi.....	88 01 20	30 59 51
Tallahassee.....	Florida and Alabama.....	84 16 38	30 26 03
Third Principal.....	Illinois.....	89 03 54	38 28 27
Uintah.....	Utah.....	109 56 06	40 25 59
Ute.....	Colorado.....	106 31 59	39 06 23
Washington.....	Mississippi.....	91 09 36	30 59 50
Willamette.....	Oregon and Washington.....	122 44 34	45 51 11
Wind River.....	Wyoming.....	108 48 49	43 09 41

¹ The numbers are entered in fractional township 29 north in Illinois, and are repeated in Wisconsin, beginning with the south boundary of the State; the range numbers are given in regular order.

Fig. 1-2. Meridians and Base Lines of U. S. Rectangular Surveys.

Each 24 square mile tract (Figure 1-6) is divided into 16 townships by locating "range" lines (division of base lines) at 6-mile intervals and "tier" lines parallel to the latitude lines every 6 miles (Figure 1-7).

A series of adjacent townships running east and west is known as a tier. An adjacent series of townships running north and south is known as a range. The tiers of townships are numbered consecutively, both to the north and south of the base line. The ranges of townships are likewise numbered, both to the east and west of the principle meridian. A township is designated by the serial number of its tier and the letter N or S to indicate the position of the tier north or south of the base line; the serial number of its range and the letter E or W to indicate the position of the range east or west of the principle meridian. (Figure 1-8).

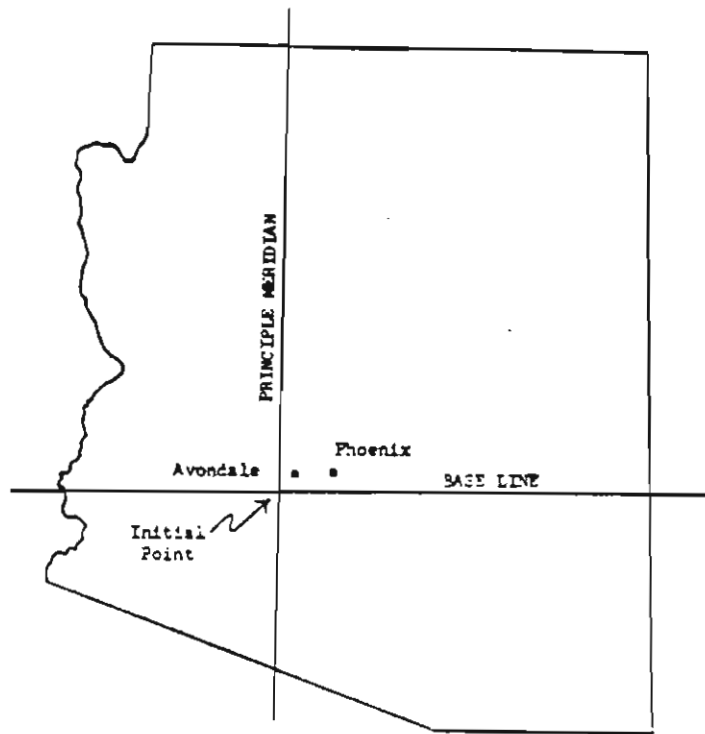

Fig. 1-3. Initial Point

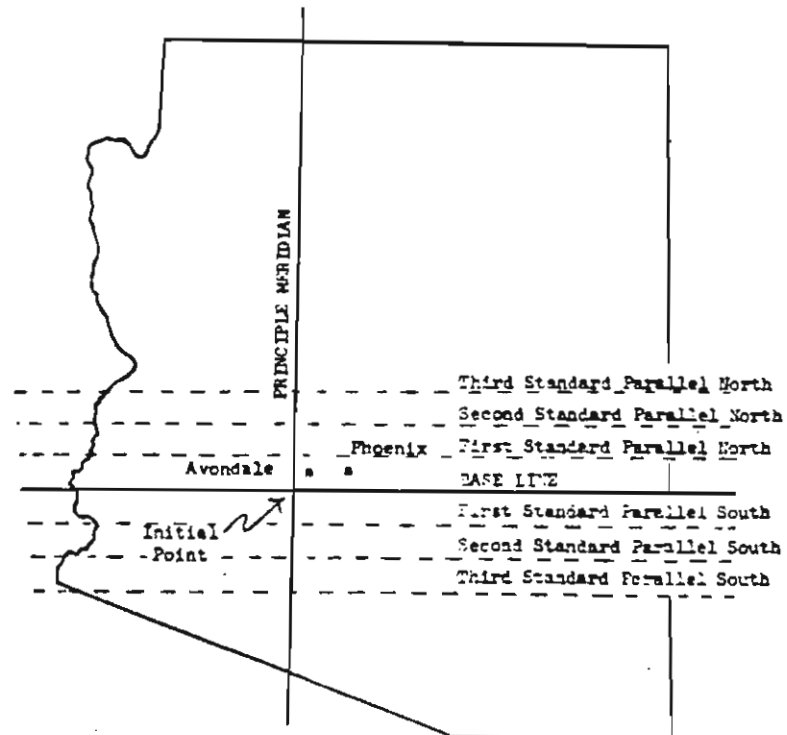

Fig. 1-4. Base Line with Standard Parallels each spaced 24 miles North and South.

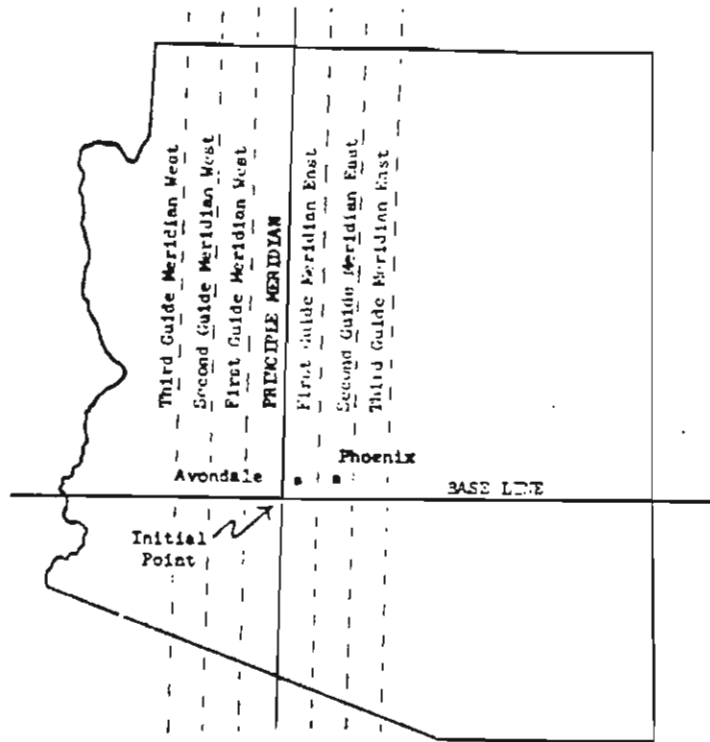

Fig. 1-5. Principle Meridian with Guide Meridians each spaced 24 miles East and West.

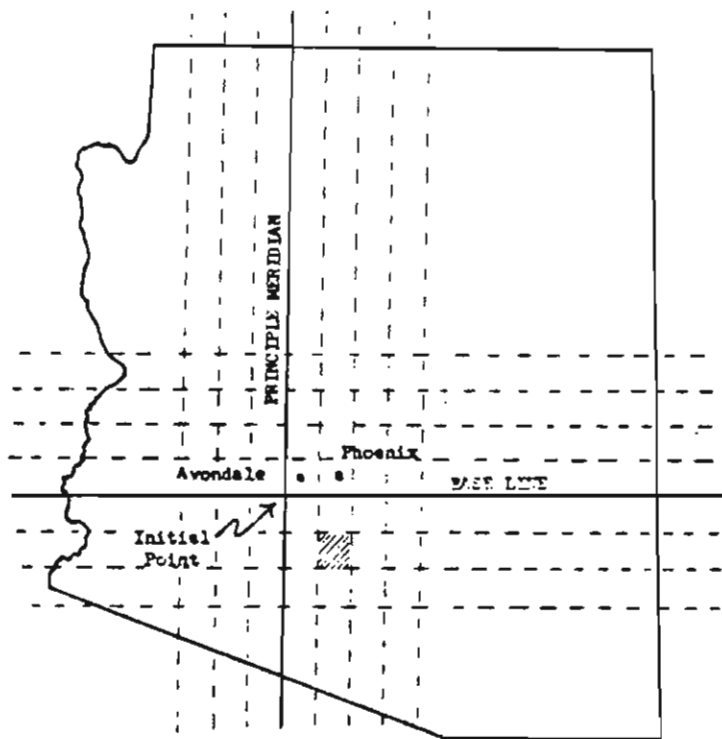
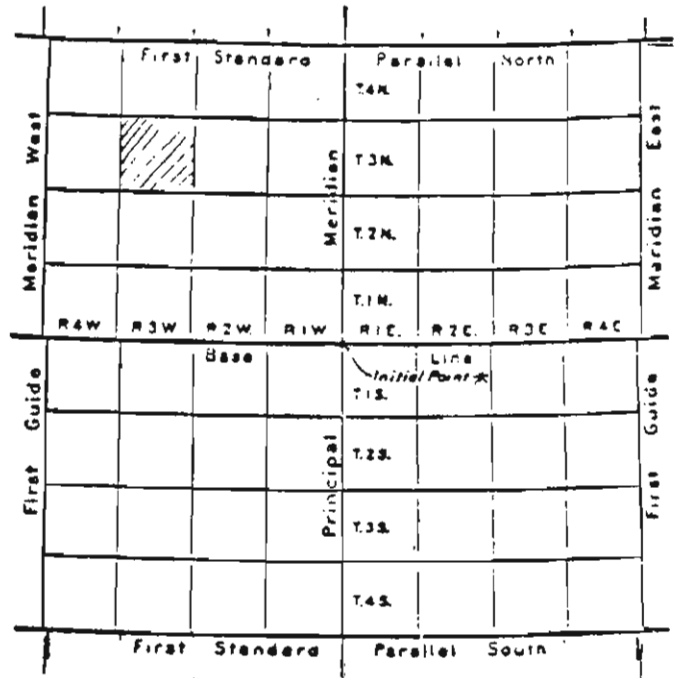



Fig. 1-6. This figure shows the Guide Meridians and Standard Parallels dividing the State of Arizona into 24-mile squares called tracts.

Fig. 1-7. This figure shows 4 tracts each divided into 16 townships.



 - Township = T3N, R3W
 *Initial Point for Arizona is near the city of Avondale.

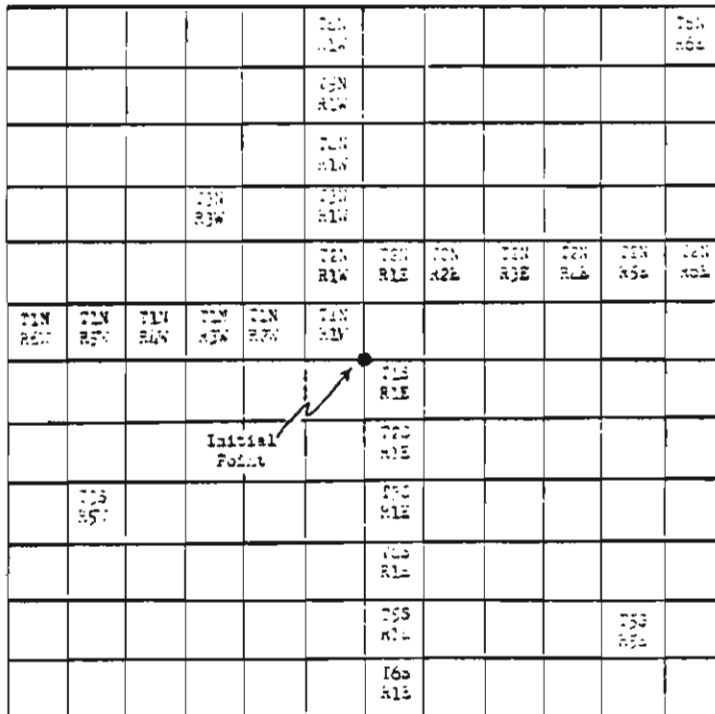



Fig. 1-8. Townships are numbered consecutively from the initial point to the north, east, south and west.

Townships are further divided into one square mile sections (640 acres). The sections are numbered by starting at the northeast corner and continuing west and east across the township until the number 36 section is found in the southeast corner of the township. (Figure 1-9).

6	5	4	3	2	1
7	8	9	10	11	12
18	17	16	15	14	13
19	20	21	22	23	24
30	29	28	27	26	25
31	32	33	34	35	36

In review, the four major steps that have been discussed concerning the Rectangular System are:

Step I Locate initial point (where the base line intersects the principle meridian). (Figure 1-10)

 - Section = No. 8

Step II Locate Standard Parallels and Guide Meridians at 24-mile intervals to form tracts of land (1 tract is 24 miles square). (Figure 1-10)

Fig. 1-9. The figure shows a Township divided into 36 sections.

Step III Divide each 24-mile tract of land into 16 equal sized Townships (1 township is 6 miles square). (Figure 1-10)

Step IV Divide each 6-mile township into 36 equal sized Sections (1 section is 1 mile square). (Figure 1-10)

The final step in the Rectangular System of Land Description is to divide up the sections and give each field or plot of land a description.

Sections can be divided into as many smaller tracts as necessary. Half or quarter sections of 320 and 160 acres, respectively, are common divisions. (Figure 1-11)

Legal descriptions always begin with the smallest unit. For example, if we wanted to describe the darkened area of the section (Figure 1-12), we would say: Northeast $\frac{1}{4}$, Section 8, Township 3 North, Range 3 West, Gila and Salt River Meridian (NE $\frac{1}{4}$, S8, T3N, R3W).

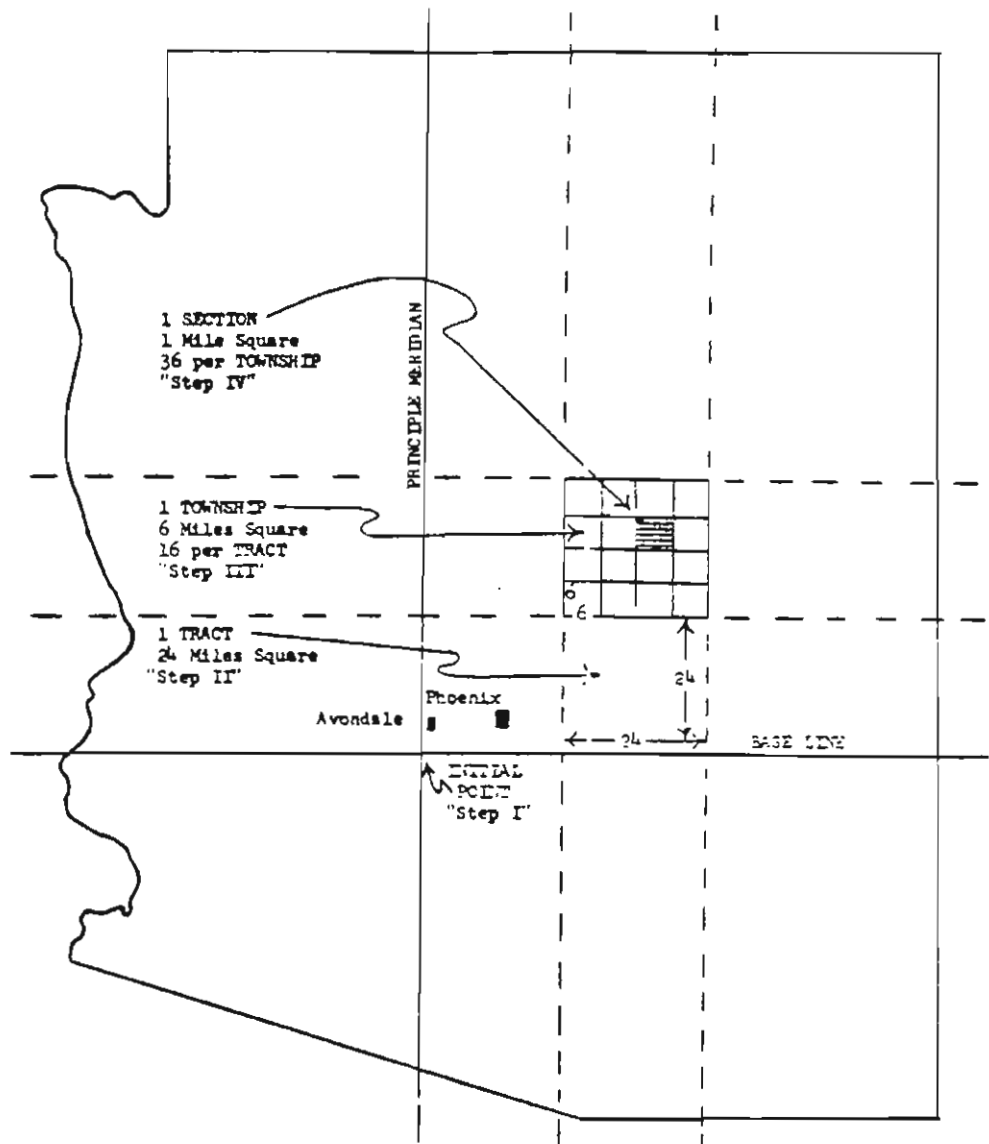

Fig. 1-10

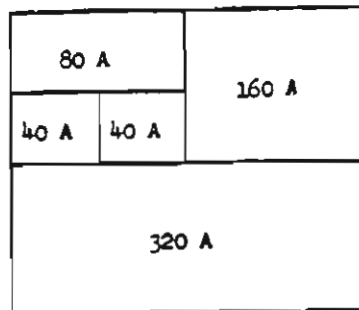
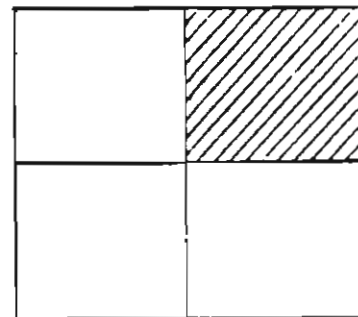
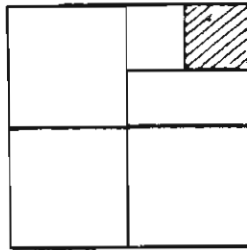

Fig. 1-11



Section 8, T3N, R3W

Fig. 1-12



NE $\frac{1}{4}$, NE $\frac{1}{4}$, Section 8, T3N, R3W
Fig. 1-13

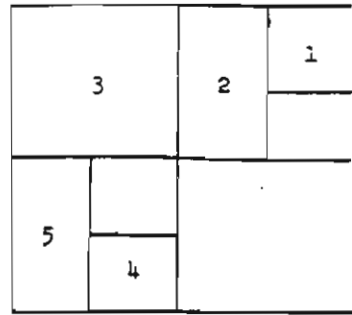

Section 8, T3N, R3W
Fig. 1-14

The parcel of land identified by the cross-sectioned area in Figure 1-13 would be described as: Northeast $\frac{1}{4}$, Northeast $\frac{1}{4}$, Section 8, Township 3 North, Range 3 West, Gila and Salt River Meridian (NE $\frac{1}{4}$, NE $\frac{1}{4}$, S8, T3N, R3W).

The legal descriptions and acreage of the parcels of land identified in Figure 1-14 are found in Table 1.

TABLE 1

Parcel	Legal Description	Acreage
1	NE $\frac{1}{4}$, NE $\frac{1}{4}$, Sec. 8, T3N, R3W	40
2	W $\frac{1}{2}$, NE $\frac{1}{4}$, Sec. 8, T3N, R3W	80
3	NW $\frac{1}{4}$, Sec. 8, T3N, R3W	160
4	SE $\frac{1}{4}$, SW $\frac{1}{4}$, Sec. 8, T3N, R3W	40
5	W $\frac{1}{2}$, SW $\frac{1}{4}$, Sec. 8, T3N, R3W	80

UNIT II

AGRICULTURAL LEVELING AND LAND MEASUREMENT EQUIPMENT

Equipment which is used in agricultural leveling and land measurement consists of tools and materials which assist the surveyor to determine changes in land elevation and distances traversed. This equipment can be the most simple or highly sophisticated depending upon the requirements of accuracy and speed necessary to satisfy the requirements of the job.

Leveling Equipment

One of the most common operations in agricultural leveling is the determination of elevation changes in land surfaces. This operation becomes essential when slope of land or construction jobs demands data associated with a level plane. A leveling instrument known simply as a level or more specifically as the tripod level is the basic tool for measuring elevation changes in land surfaces.

Principle of Operation:

Use of a leveling instrument may be illustrated by comparing it to a carpenter's level. Imagine a carpenter's level fitted with a supporting tripod and a set of sights. If the level is held so that its bubble is in the center of the vial and a sight taken across it, the line of sight will be a level line. Every point along the level line of sight is at the same elevation. It can be used as a reference line to determine the difference in elevation of points on the ground which fall directly below the line of sight.

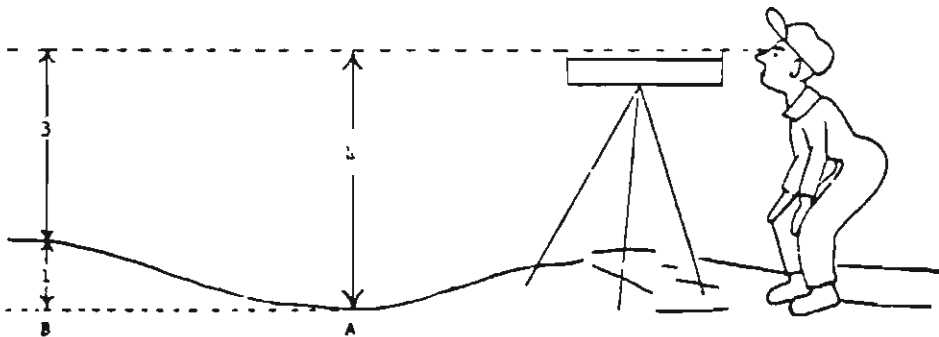

Fig. 2-1. Measuring down from the level line of sight to find the difference in elevation between two points.

In Figure 2-1, a measurement from the line of sight down to the ground at Point A shows that the elevation of the ground at that point is four feet below the line of sight. A similar measurement at Point B on the ground shows that it is three feet below the line of sight. Point A is then found to have an elevation one foot lower than Point B.

Types of Levels:

There are a number of types of levels on the market and are purchased through local hardware dealers or ordered direct from the manufacturers.

Levels range in price from \$100 to approximately \$1500. A farm level which costs about \$100, complete with tripod, will serve excellently in surveying for land leveling and all other farm work involving the distribution of water. A surveyor's level is a more highly refined instrument and is intended for more exacting measurements than can be obtained from the lower cost instrument.

Leveling instruments of the various types are identified by the primary use for which they are intended. Generally these include the Dumpy Level (Figure 2-2), Transit (Figure 2-3), Contractor's Level (Figure 2-4), Farm Level (Figure 2-5), and Automatic Levels (Figure 2-6).

Dumpy level - The dumpy level is a rigidly constructed level in which the telescope tube, vertical supports, and horizontal bar are all made in one casting (Figure 2-2). A set of 4 leveling screws are used to level the instrument to the horizontal plane.

Dumpy levels are widely used for conducting profile and differential surveys associated with the planning and staking out erosion control, drainage and irrigation structures. The instrument is also used to lay out building foundations, and for running straight lines.

Transit - The transit and transit-level is constructed to permit the telescope tube to not only move sideways 360 degrees but in a limited vertical plane. (Figure 2-3 & 2-7)

A full transit is an instrument with a telescope tube that is able to revolve vertically a full 360 degrees. This makes it possible to take an exact opposite reading without disturbing the horizontal settings simply by rotating the tube 180 degrees in the vertical plane.

The transit and transit-level is used to lay out roads, streets, building lines, ditches, orchards, fences, hedges, fields, etc. It can also be used to establish vertical lines and planes for building walls, fences, and plumbing windows and doors.

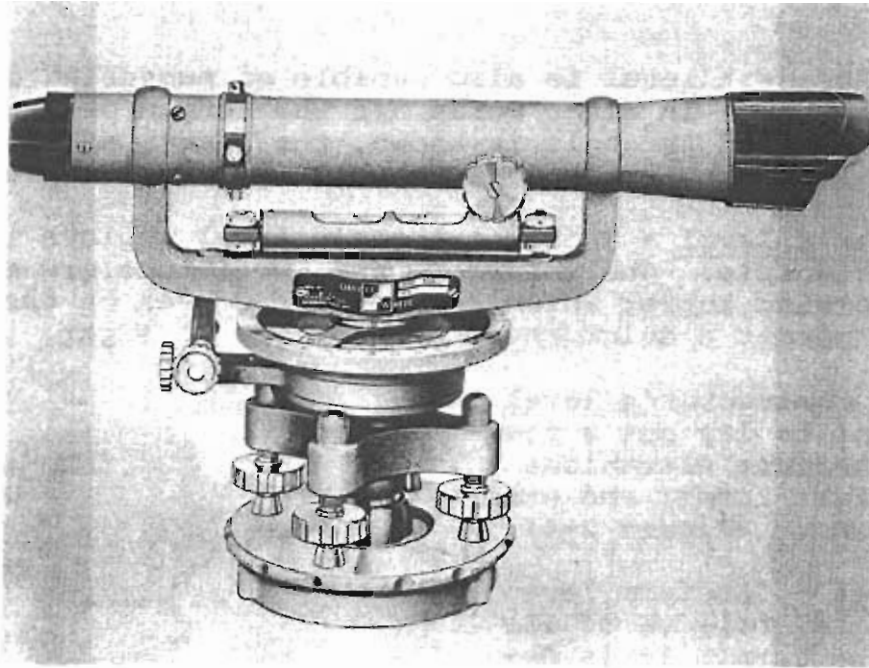

Fig. 2-2. Dumpy Level
(Courtesy of David White Instruments)

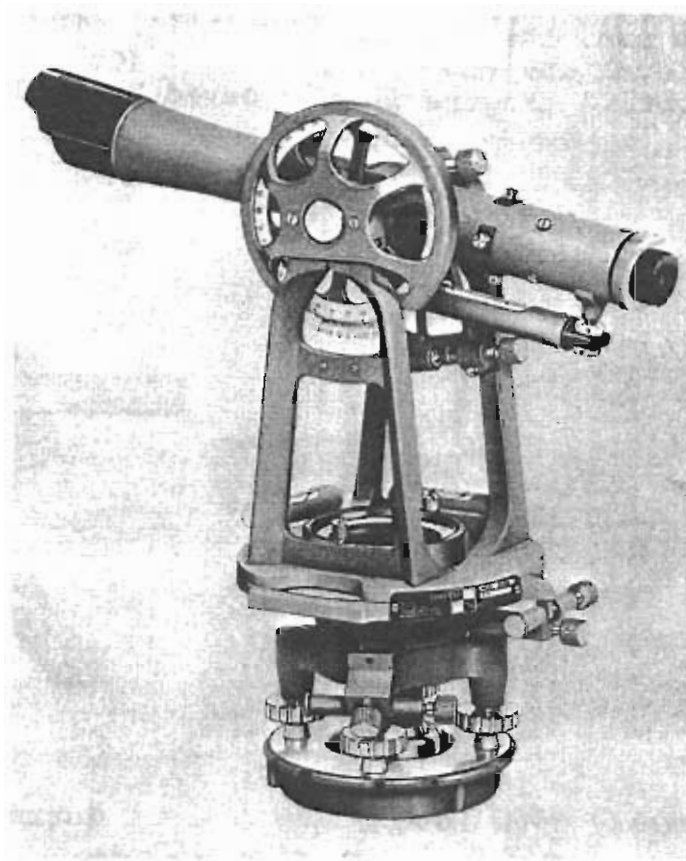

Fig. 2-3. Transit
(Courtesy of David White Instruments)

The transit level is also capable of measuring distances by calculation. In other words, if the length of one side of a three-sided triangle is known, the length of the remaining sides can be computed from the vertical angle sighted.

Contractor's level - The contractor's level employs the turret principle. The telescope and level tube are mounted in a revolving turret which can be turned over on the leveling plate to permit a quick check of the line of sight.

The contractor's level is often used to lay out a foundation, measure elevations, run straight lines, and other simple jobs. (Figure 2-4)

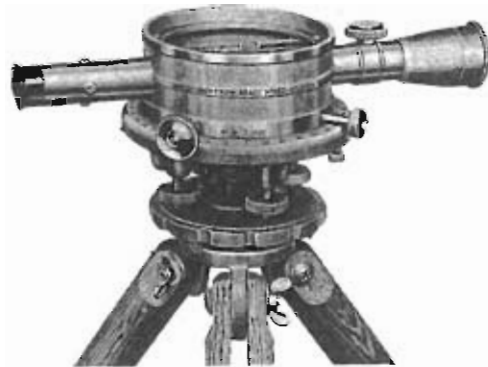
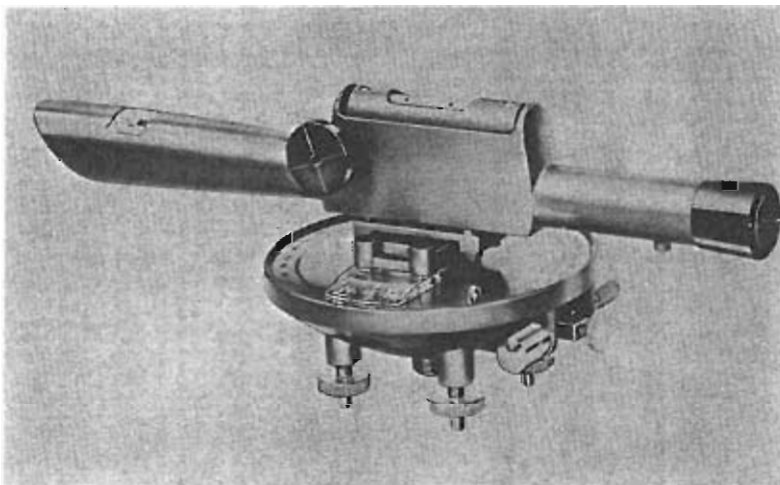

Fig. 2-4. Contractor's Level
(Courtesy of David White Instruments)

Farm level - The farm level is so called because of its use on the farm. It is designed and built for use by farmers, carpenters, builders and contractors who have need for a lightweight, dependable and inexpensive instrument. There are two common types of farm levels in use, the utility type level and the turret type level. (Figure 2-5)



Utility Type Level



Turret Type Level

Fig. 2-5. Farm Level
(Courtesy of David White Instruments)

The farm level is used by farmers for contour mapping, land leveling for proper irrigation, laying out building foundations, measuring elevations, grading, drainage, terracing and other agricultural jobs.

Automatic level - The automatic level or the self-leveling level is a highly sophisticated instrument. Once the instrument is leveled it will maintain its level automatically. This has the advantage of offering very rapid instrument set-ups and of eliminating errors in centering the level bubble in the leveling tube.

This type of level is very expensive and is used for very accurate measurements. It is mostly used by engineers in dam construction, coastal surveys, construction of missile launching sites, golf course construction and other work requiring extremely accurate, rapid measurements. (Figure 2-6)

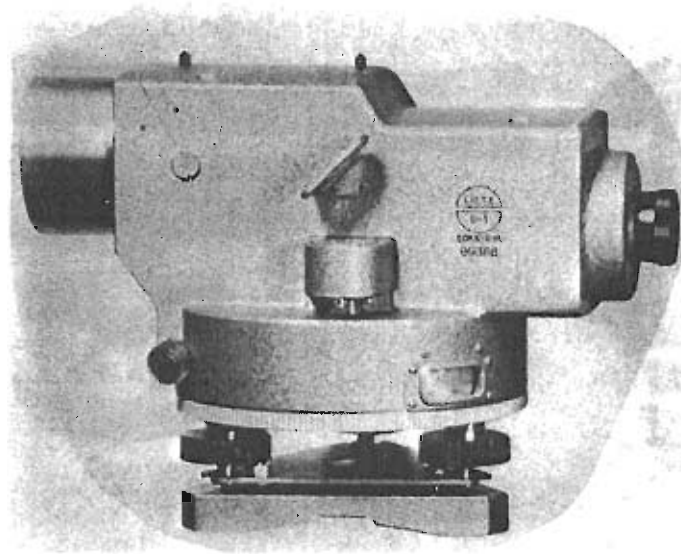

Fig. 2-6. Automatic Level
(Courtesy of Lietz)

Transit vs. level - Many people are confused as to the exact difference between a transit and a level. The difference lies in its' construction and use. (Figure 2-7)

The transit and transit-level have more uses than an ordinary level, primarily because the telescope tube is not only capable of moving 360 degrees from side to side, but can be moved up and down 45 to 360 degrees. It can measure both vertical and horizontal angles.

The transit and transit-level can be used to plumb walls, stake out a fence, measure vertical distances by calculation and similar operations which cannot be performed by the common level.

Additional equipment used to complement the leveling instrument includes the tripod (Figure 2-8), plumb bob (Figure 2-9), and leveling rod (Figure 2-10).

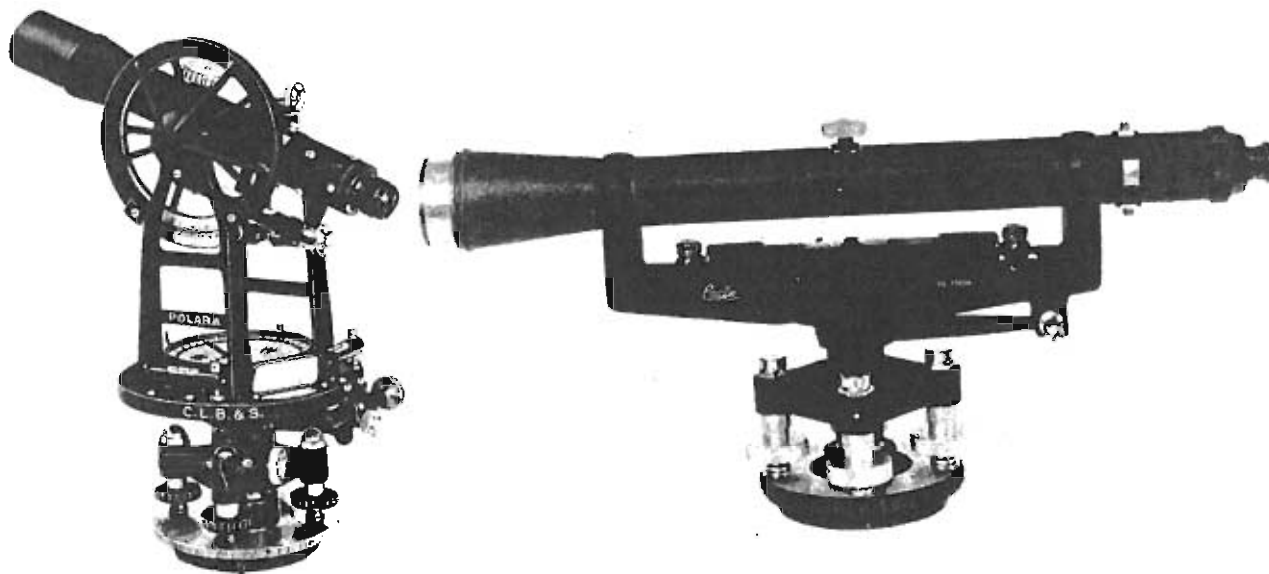

Transit

Level



Transit Level

Fig. 2-7.

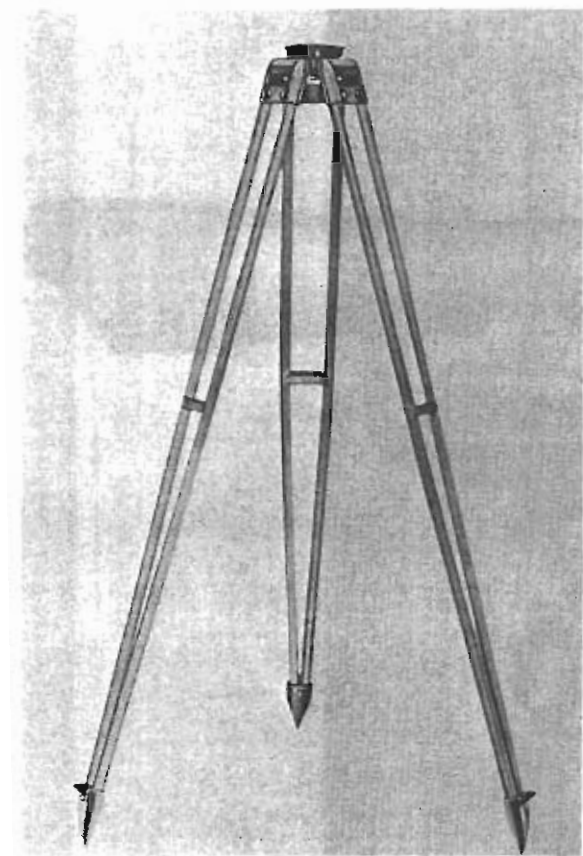

Fig. 2-8. There are wide selections of tripods to fit all classes and models of leveling instruments.

(Courtesy of David White Instruments)



Fig. 2-9. Plumb bobs are precision machined from solid brass. They can be purchased in different weights ranging from 6 oz. to 24 oz.

(Courtesy of David White Instruments)

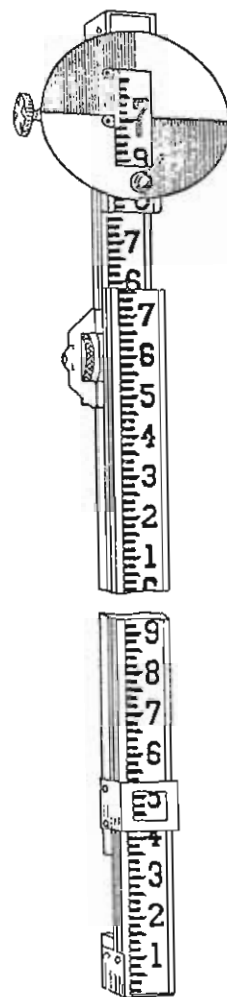

Fig. 2-10. Leveling Rod with metal target.

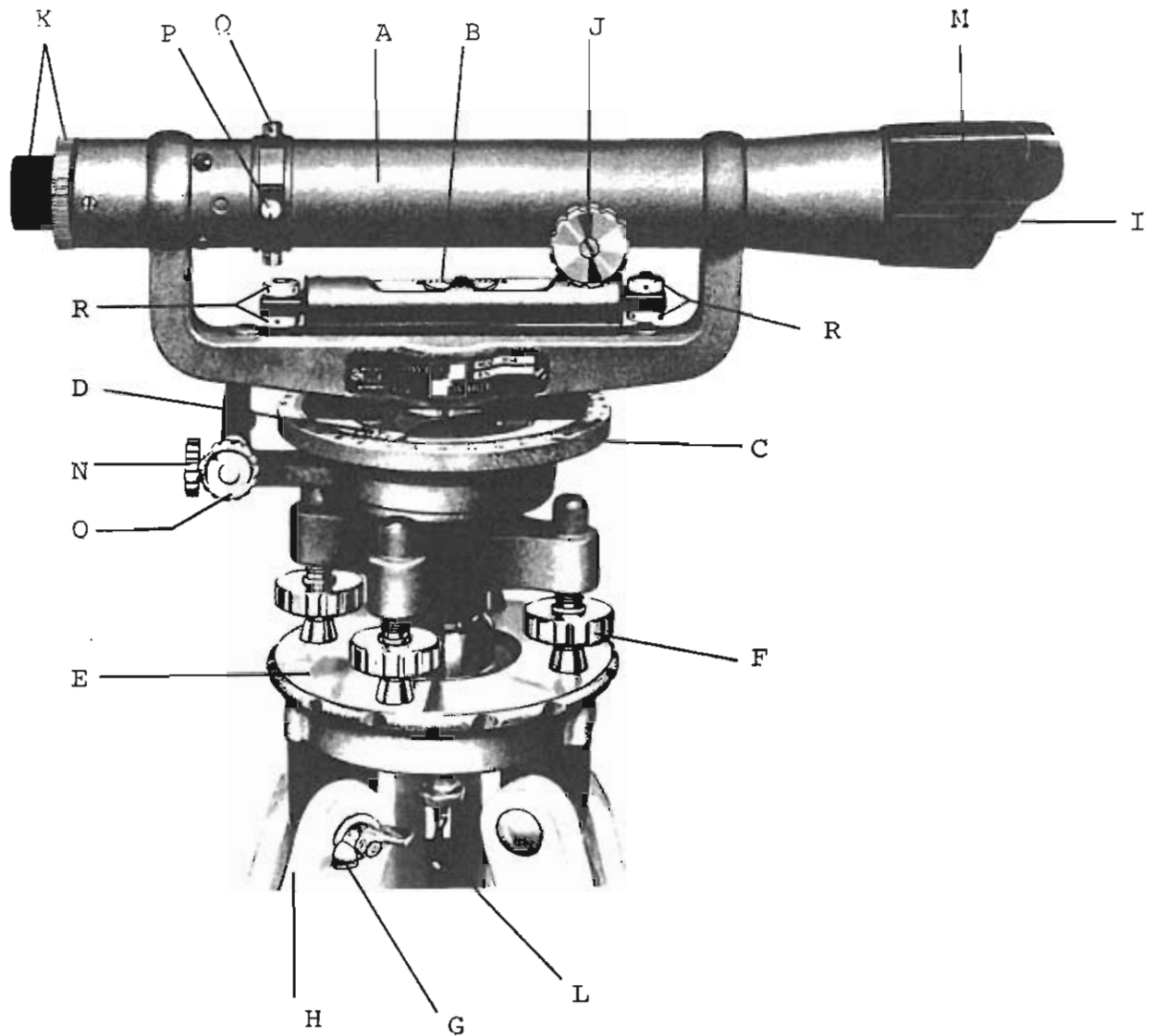

Fig. 2-11. Parts of the Leveling Instrument

- | | |
|--|---|
| A - Telescope tube | K - Eyepiece & cross hair focus |
| B - Level tube and bubble | L - Plumb bob attachment |
| C - Azimuth (degrees) | M - Sunshade |
| D - Index or witness mark
(minutes) | N - Azimuth locking screw |
| E - Base plate | O - Fine adjustment (azimuth) |
| F - Leveling screw | P - Horizontal cross hair
adjustment |
| G - Friction wing nut | Q - Vertical cross hair
adjustment |
| H - Tripod leg | R - Level tube adjusting
screws |
| I - Objective | |
| J - Objective focus screw | |

Parts of a Level and Their Function:

Leveling instruments, regardless of how simple or complex, are constructed of parts which are similar in shape and function. The most obvious part of the leveling instrument is the telescope tube. This part of the level serves as a sighting device and enlarges the image of any viewed object. The telescope is a precision optical instrument containing a set of lenses that give a clear magnified image. Leveling instruments can be purchased with telescopes of varying power. A 20-power telescope makes an object seem 20 times closer than when viewed with the naked eye. Naturally, the greater the magnification, the greater the distances over which the instrument can be used. The eyepiece and cross hair focus is located at the sighting end of the telescope tube. It is used to adjust the focus on the cross hairs. The cross hair in the telescope is used to align or center the line of sight with a particular object. The objective focus screw is used for adjusting the objective lens of the telescope to focus upon the view. The objective is a compound lens that forms an image of the object being sighted. It is mounted in the telescope tube at the end opposite the eyepiece. The sunshade located at the objective end of the telescope tube, reduces glare caused by the sun. On some instruments this is an attachment while on others it is a permanent part of the tube. Directly below and parallel to the telescope tube is the level tube. This tube is an indicator of levelness of the line of sight and consists of a glass tube that is filled almost completely with liquid and sealed at both ends. The liquid is normally either alcohol or ether because neither chemicals freeze at low temperatures. The level tube is marked with graduations equally spaced from both ends. When the bubble (caused by a small amount of air riding on top of the liquid in the level tube) is centered between the graduations, the line of sight is level. (See Figure 2-12) Directly below the telescope tube is a circular plate called the azimuth. The plate is graduated in degrees. It is very much like a protractor used in school except that it makes a complete 360 degree circle. The index or witness mark identifies the degrees on the azimuth to which the telescope tube has been turned. Often times the index is marked to allow reading the azimuth to minutes of a degree.



Bubble off-center



Bubble centered

Fig. 2-12 - Level tube

Leveling instruments have four leveling screws which are supports for adjusting the level tube to the level position. The base plate is a support for these leveling screws. It also serves as an attachment to the supporting tripod legs and plumb bob. The plumb bob attachment is located on the bottom side of the base plate. It serves as a central point of attachment for the plumb bob which is used to center the instrument over a specific point. The tripod leg is one of three supporting legs to steady the instrument. The ends of the legs are steel tipped so that they may be pushed into the ground. Friction wing nuts securely clamp the tripod legs to the base plate to provide a steady support.

Proper Care of the Leveling Instrument:

The following rules of proper care and use are suggested for tripod levels:

1. Always transport a leveling instrument in its carrying case when moving from one site or location to another. Place the carrying case in a location in the vehicle where it will not receive undue vibration or jolts.
2. Carry lens and tripod caps in the instrument box after removing them to avoid loss.
3. Never force or over tighten leveling screws. Finger snugness is the rule.
4. Protect the lens from direct sun rays. Use the lens sunshade at all times.
5. Loosen tripod leg friction wing nuts before setting up or moving tripod.
6. Carry instrument when attached to the tripod under arm with instrument forward. Never carry instrument over the shoulder for fear of turning and swinging instrument into some object and damaging it.
7. Use lens tissue to clean lens -- remove dust with a camel's hair brush.

Land Measurement Equipment

The process of making measurements in leveling requires a combination of human skills and mechanical equipment applied with the utmost judgment.

Measurement of agricultural land is necessary in order to determine acreage. We do this by means of steel tapes, measuring wheels and pacing.

The idea of measuring one object by comparing it with another is probably older than written history, while the concept of measuring an object by comparing it with an "approved standard" goes back many hundreds of years. When the quantity being measured was length or distance, many "approved standard units" came into use -- the first being derived from physical dimensions of the human body. For example, the inch, palm, hand, span, foot cubit, pace, yard, and fathom can all be traced to human anatomy.

Although most people have measured objects with a "yard stick", few realize that a "king sized" yard stick or "pole" sixteen and a half feet long, was once common. This unit is also known as the "rod". Of course, the long pole proved to be a very awkward measuring tool to use, but the "rod" still remains as a common unit of land measure.

The need for a "tool" with which to measure long horizontal distance was probably first fulfilled by using a piece of rope of a known length. The increased convenience of such a flexible device in place of a long pole is obvious, but the increased convenience also introduced a new possible source of error, namely uncalibrated stretch.

Ropes were later replaced by chains of various "standard" lengths, most of them either 100 feet or 66 feet long.

With the advent of high strength steel, a narrow steel ribbon or "tape" was developed which replaced the chain. The steel tape provided greater accuracy and convenience than the chain. It also weighed less and could be marked with any desired graduations. Although chains are no longer used (except on the football field), the term "chainman" persists and probably will for years to come to identify the land measuring process by steel tape.

Land Measurement Methods:

The methods which may be used to measure distances for agricultural applications include pacing, steel tape, measuring wheel, stadia and electronic measuring equipment.

Pacing - Pacing consists of determining the average length of normal steps or paces. For example, if you counted 30 steps or paces in a length of 100 feet, your average pace would be 3.33 feet.

$$\frac{100 \text{ feet}}{30 \text{ paces}} = 3.33 \text{ feet/pace}$$

The length of the human pace varies with the individual, with the rate of speed, and the terrain. For example, a tall man's pace may be longer and slower than a short man's. An individual's pace will be longer on level and smooth terrain than it would be on rough and hilly lands. A pace of one yard length is assumed. For many individuals it is difficult to maintain this length pace uniformly and results are not satisfactory, especially for long distances. Accordingly, the best practice is to use a pace that is a natural step and an average gait.

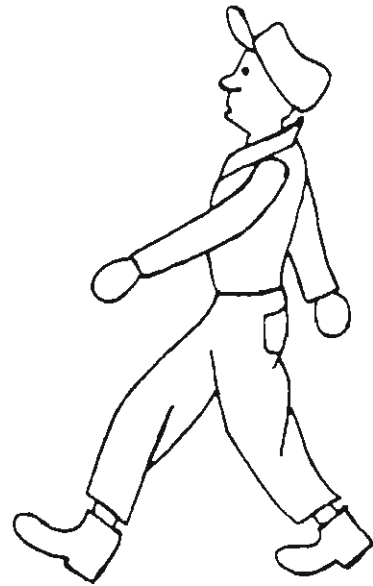

The number of paces per 100 feet can be accurately determined by laying the tape (100 foot steel tape) out on a level ground surface and pacing its length at least four times. The total number of paces is divided by four to obtain the average number per 100 feet.

What is the length of your pace?

Taping - The steel tape is considered by many agricultural workers to be the most accurate tool for practical land measuring operations. Measuring with a steel tape is very often called chaining; in fact, the party of two men required to measure with a steel tape are often referred to as rear and head "chainmen". The accuracy of measuring with the tape is determined by the knowledge of the equipment and the skill of properly using, reading and recording measurements.

1. Reel-type steel tapes (Figure 2-13) used in most agricultural work are available with two types of graduations. One of the more common arrangements of graduating the tape is shown in Figure 2-14a. With this particular type tape there is a blank space at each end. The first foot starting with zero is graduated in

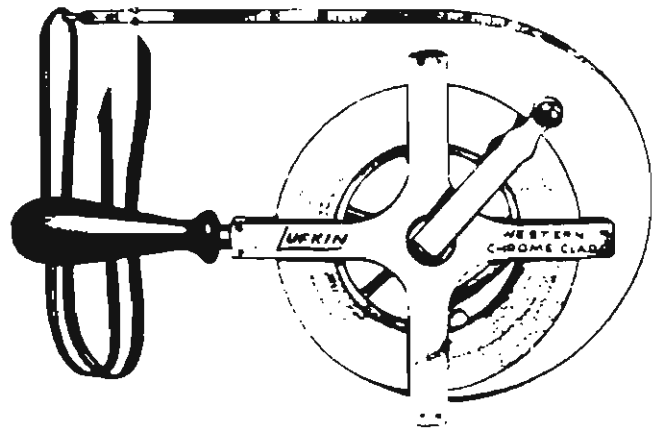

Fig. 2-13. Reel-type Steel Tape
(Courtesy of Lufkin)

10ths and 100ths numbered in a forward direction. The remainder of the tape is graduated every foot. Figure 2-14b illustrates another commonly used method in graduating steel tapes. This tape also has a blank space at each end but unlike the other tape has an extra foot before zero. This extra foot is graduated in 10ths and 100ths numbered in a backward direction. The remainder of the tape is graduated every foot.



-a-



-b-

Fig. 2-14a & b. Two commonly used methods of graduating steel tapes.

(Courtesy of Lufkin)

2. Set of eleven chaining pins (Figure 2-15) on a suitable carrying ring (Figure 2-16).

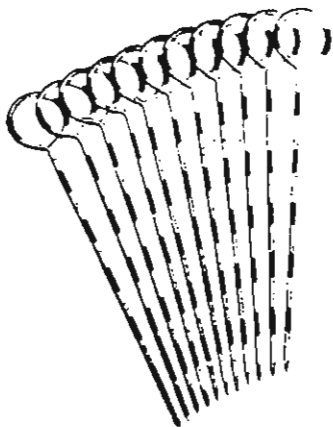

Fig. 2-15. Set of eleven Chaining Pins.

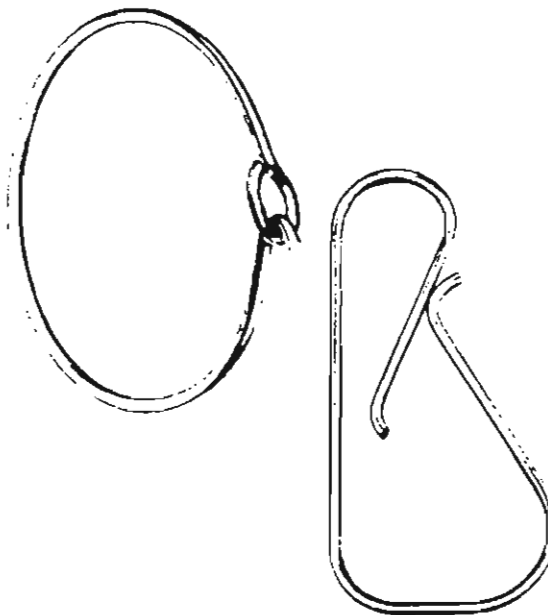

Fig. 2-16. Carrying Rings for Chaining Pins

(Courtesy of Lufkin)

3. Plumb bob - For use when measuring land that is quite rough or uneven. The plumb bob is necessary in order to measure a true horizontal distance. (Figure 2-17)

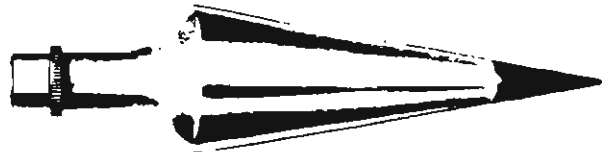

Fig. 2-17. Plumb Bob
(Courtesy of David White Instruments)

4. Range poles - Alternately painted red and white poles are used as upright guides when chaining or for marking turning points. (Figure 2-18)

The principle sources of error in measuring horizontal distances with a steel tape are:

1. Incorrect length of tape - Under field conditions, the actual length of a steel tape is seldom exactly its designated length. For example, the designated length of 100.00 feet will only occur when at standard temperature and tension (usually 68° F and a tension of 10-12 pounds). A tape which has been damaged and repaired may not be accurate.

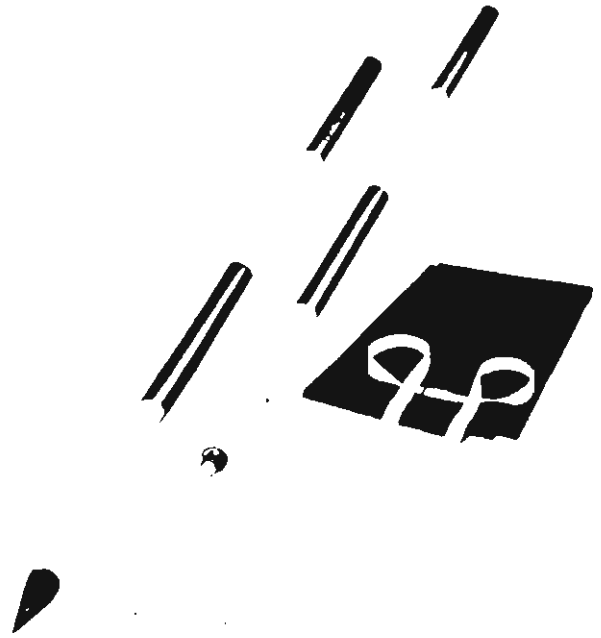

Fig. 2-18. Range Pole

It is obvious that every tape length measured with a tape of incorrect length will be in error directly proportional to the number of tape lengths measured.

Extreme care should be given to avoiding "kinks" in a tape since the accuracy of the tape will be destroyed. Care should also be taken to store tapes on a reel in a dry condition to prevent rust and corrosion.

2. Tape not horizontal - If a steel tape is not held level and is actually higher on one end, the distance measured will be greater than actual. For example, if one end of a 100 foot tape is 1.41 feet higher or lower than the other, the error will amount to .01 feet. If the height is doubled to 2.82 feet the error will increase to .04 feet.

Errors of this type are cumulative and may be considerable when measuring over hilly ground.

3. Miscounting number of pins - Accuracy in chaining may be ruined by a careless count of the chaining pins. The serious mistake of omitting or adding a pin can be prevented by following an orderly procedure and careful attention to the work.

4. Incorrect tension - The error caused by applying incorrect tension is relatively unimportant. An increase of 10 lbs. in tension on a light tape (1 lb) will stretch a 100 foot tape about 0.013 feet. The same increase on a heavy tape (3 lbs), will produce a change in length of about 0.003 feet.

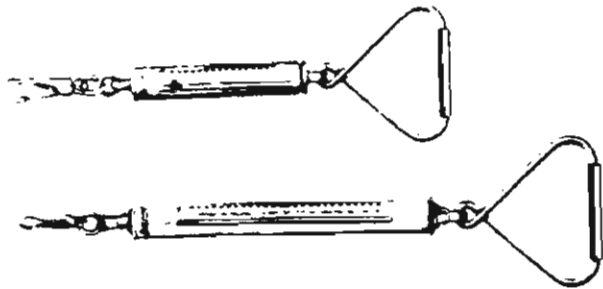

Fig. 2-19. Proper tension is applied to the tape by use of a spring scale.

(Courtesy of Lufkin)

On work requiring accurate measurements, a spring scale is used for maintaining a constant tension. (Figure 2-19)

5. Sag - As the tape is lifted from a flat surface sag in the tape will shorten the distance between the two ends. A sag in the center of a 100 foot tape can cause an inaccurate measurement. A 5/16" tape normally sags about 7 3/8 inches below the two ends and will cause the measured distance to be short by 0.01 feet. Error can be eliminated by always applying equal tension, thereby compensating for the effect of sag by adding above correction factor to each tape length.
6. Incorrect alignment - If a field measurement comprises more than one tape length and the points marking the ends of the various lengths along the route are not along a straight line, the measured distance will be in error. For measurements of high precision the tapemen can be kept on line with a level (transit).

7. Tape not straight - If the steel tape is not stretched straight, as when it is being bent either horizontally or vertically around trees or bushes, or is blown by a strong wind, the measured length will be too great. For example, if the middle point of a 100 foot steel tape is $8\frac{1}{2}$ inches off line, the resulting error in length is 0.01 feet. (The least error will occur when the bend is near the middle of the tape.)
8. Random errors - Random errors are introduced into taping from several causes. These errors include: (1) failure to apply proper tension, (2) wind deflecting the plumb bob, (3) inability of the tapeman to steady the plumb bob, (4) inability of the observer to estimate the last place in reading between tape graduations, and (5) others.

Measuring Wheels - One of the quickest and easiest methods of measuring distances is the measuring wheel (Figure 2-20). The measuring wheel is designed to measure distances on flat or smooth surfaces and can be operated while walking or driving a vehicle (Figure 2-21).

Distances are measured using the measuring wheel by multiplying the number of revolutions recorded on the counter by the circumference of the wheel. For example, if the counter reads 7 revolutions and the wheel circumference is 6.6 feet, the distance covered is 46.2 feet.



Fig. 2-21. Using the Measuring Wheel while operating a vehicle

(Courtesy Rolatape, Inc.)

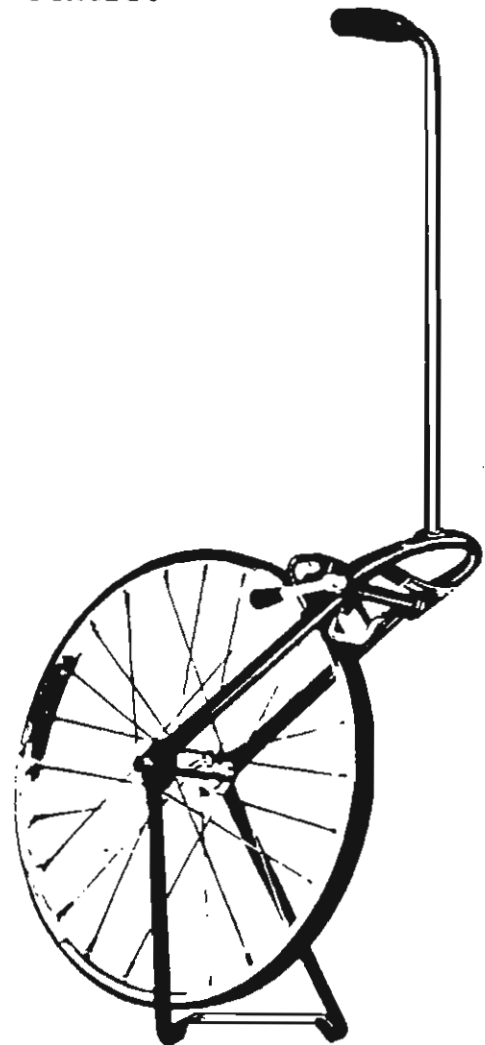

Fig. 2-20. Measuring Wheel

(Courtesy Rolatape, Inc.)

EXAMPLE:

Circumference of Wheel	6.6 feet
Revolution of Wheel	x7
	<u>46.2</u> feet

Acreage measurements are obtained simply by multiplying the number of revolutions in the length of the field by the number of revolutions in the width. Each revolution of the wheel is recorded on an automatic counter; divide the answer by 1000 by moving the decimal three places to the left.

EXAMPLE:

Length of Field	125 revolutions
Width of Field	x 30 revolutions
	<u>3750</u> revolutions
Acreage	= 3.750 acres

Stadia - The stadia method of measurement provides a rapid and efficient means of determining distances and differences in elevation. It can be used in agriculture for contouring and also differential and profile leveling.

The term "stadia" comes from the Greek word for a unit of length originally applied in measuring distances for athletic contests. "Stadia" is now used to describe the cross hairs in some leveling instruments as well as to the stadia method itself. Not all leveling equipment is equipped with stadia hairs.

A more detailed discussion of measuring lineal distances by stadia is presented in Unit III.

Electronic measuring equipment - Electronic measuring instruments called geodimeters (Figure 2-22) are used when an extremely accurate measurement is needed. The maximum error using this instrument for a single measurement is .005 feet/mile, which is less than 1/16 inch per mile. Here is how it works: The geodimeter projects a modulated beam of light to a reflector (Figure 2-23) which is placed at the opposite end of the distance to be measured. The light is reflected back to the instrument where a comparison is made between the outgoing and incoming light pulses. The geodimeter can be used to measure distances across water,

along roads, and in cities and construction areas (Figure 2-24 where there are no obstructions to the light beam.

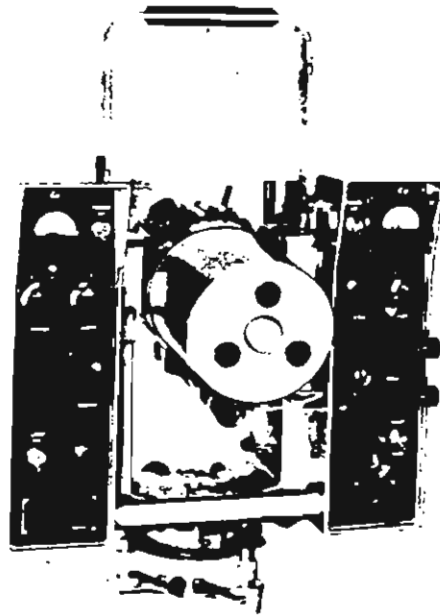

Fig. 2-22. Geodimeter
(Courtesy of Surveyors
Service Company)

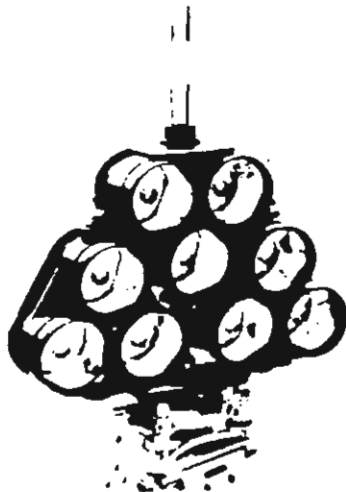
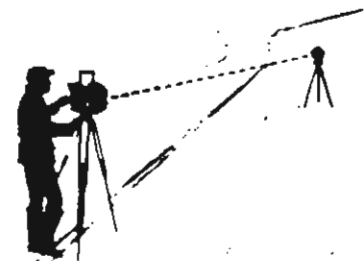

Fig. 2-23. Reflector
(Courtesy of Surveyors
Service Company)



ACROSS WATER
Bridge and Jam construction. No interference from
surface reflections or passing ships.



ALONG ROADS
Accuracy unaffected by passing traffic, power lines, etc.

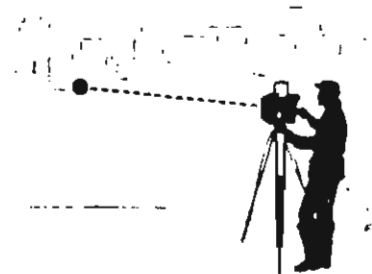

IN CITIES AND CONSTRUCTION AREAS
City surveying and boundaryline measurement are
typical surveying jobs for AGA Geodimeter.

Fig. 2-24. The Geodimeter can be used to measure distances across water, along roads, and in cities and construction areas.

(Courtesy of Surveyors
Service Company)

Determining Land Acreage

Land measuring applications in agriculture are directly related to determining field boundaries and the exact quantity of land expressed in acres contained within the boundaries. An acre of land is expressed in numerical terms as 43,560 square feet projected in a horizontal line of sight. Providing the lineal distance in feet is known, one may obtain square feet by applying the mathematical principles of geometry. The following examples of determining acreage are typical of most agricultural applications.

Field or land areas that are square or rectangular in shape can be converted to acreage by first multiplying the width in feet times the length in feet and dividing the product by the number of square feet in an acre.

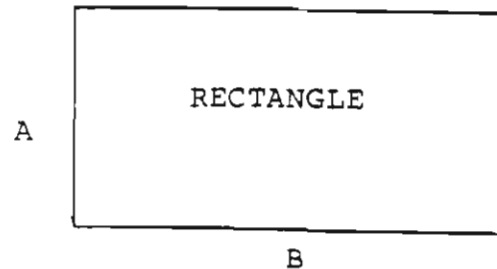
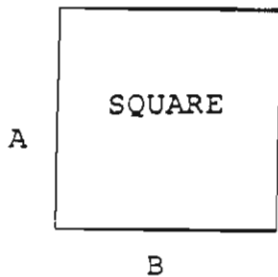

$$A \times B = \text{Area}$$

EXAMPLE: Mr. Smith has a barley field 2,000 feet long and 500 feet wide. What is the area of his barley field?

$$\text{Area} = \text{length} \times \text{width}$$

$$\text{Area} = 2000 \text{ ft.} \times 500 \text{ ft.} = 1,000,000 \text{ sq. ft.}$$

To convert this to acres divide 1,000,000 sq. ft. by 43,560 sq. ft./acre

$$\frac{1,000,000 \text{ sq. ft.}}{43,560 \text{ sq. ft./acre}} = 43.56 \text{ acres}$$

Mr. Smith has $43\frac{1}{2}$ acres of barley

Similarly the area of a triangularly shaped area will be equal to one-half the base times the altitude.

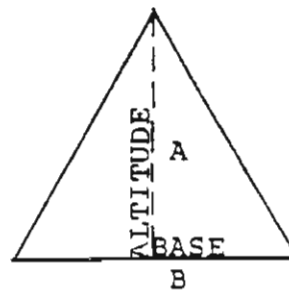
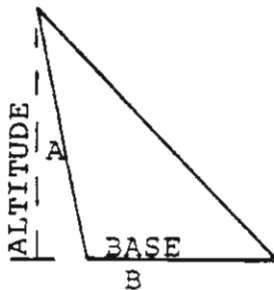

$$A \times \frac{1}{2} B = \text{Area}$$

EXAMPLE: Mr. Jones has a corn field shaped like a triangle and wants to find its area. How does he do it?

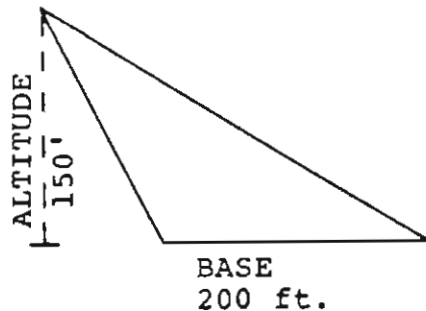

$$\begin{aligned} \text{Area} &= \text{altitude} \times \frac{1}{2} \text{ base} \\ \text{Area} &= 150 \text{ ft.} \times \frac{200 \text{ ft.}}{2} \\ \text{Area} &= 150 \text{ ft.} \times 100 \text{ ft.} \\ \text{Area} &= 15,000 \text{ sq. ft.} \end{aligned}$$

To convert this to acres divide 15,000 sq. ft. by 43,560 sq. ft./acre

$$\frac{15,000 \text{ sq. ft.}}{43,560 \text{ sq. ft./acre}} = .34 \text{ acres}$$

Mr. Jones has about 1/3 of an acre of corn.

The area of a field with two sides parallel is found by measuring the lengths of two parallel sides, adding them together, dividing by two to determine the average length, and then multiplying this by altitude or width.

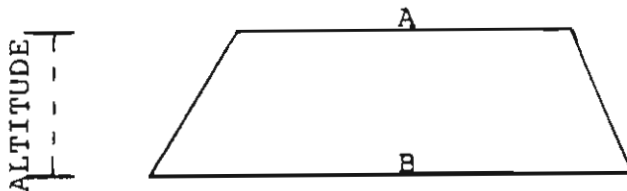

$$(A+B) \div 2 \times \text{Altitude} = \text{Area}$$

EXAMPLE:

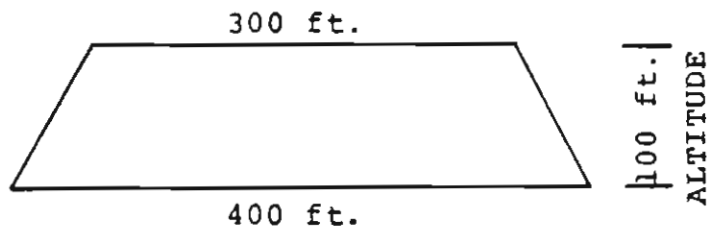

$$\begin{aligned} \text{Area} &= (400 \text{ ft.} + 300 \text{ ft.}) \div 2 \times 100 \text{ ft.} \\ \text{Area} &= 700 \text{ ft.} \div 2 \times 100 \text{ ft.} \\ \text{Area} &= 350 \text{ ft.} \times 100 \text{ ft.} \\ \text{Area} &= 35,000 \text{ sq. ft.} \end{aligned}$$

To convert this to acres divide 35,000 sq. ft.
by 43,560 sq. ft./acre

$$\text{Acres} = \frac{35,000 \text{ sq. ft.}}{43,560 \text{ sq. ft./acre}}$$

Acres = .80 or 8/10 of an acre

To find the area of a field having four or more sides,
divide it up into triangles, figure the area of each triangle
separately, and then add them together.

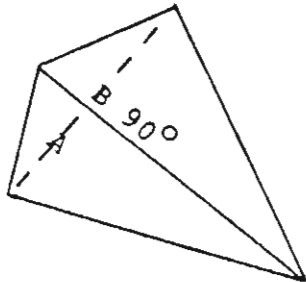

Area Triangle A + Area Triangle B
in sq. ft. = Area

EXAMPLE:

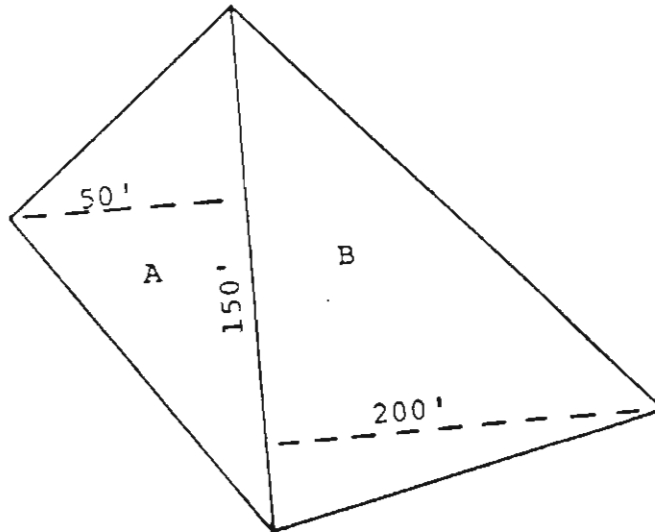

Area of Triangle A = 3750 sq. ft.

Area of Triangle B = 15,000 sq. ft.

$$\begin{aligned} \text{Total area of field} &= \text{area triangle A} + \\ &\quad \text{area triangle B} \\ &= 3750 \text{ sq. ft.} + 15,000 \text{ sq. ft.} \\ &= 18,750 \text{ sq. ft.} \end{aligned}$$

To convert this to acres divide 18,750 sq. ft.
by 43,560 sq. ft./acre

$$\frac{18,750 \text{ sq. ft.}}{43,560 \text{ sq. ft./acre}} = .25 \text{ or } 1/4 \text{ acre}$$

If one boundary of a field is an irregular curved line, one or more straight lines, such as AB, should be laid out. Offsets perpendicular to AB, as shown by short dotted lines at uniform intervals, should be measured. The area between lines AB and the curved boundary is measured as follows: Take the sums of the two end offsets and divide by two; to this add the sum of all other offsets and multiply by the uniform distance between offsets.

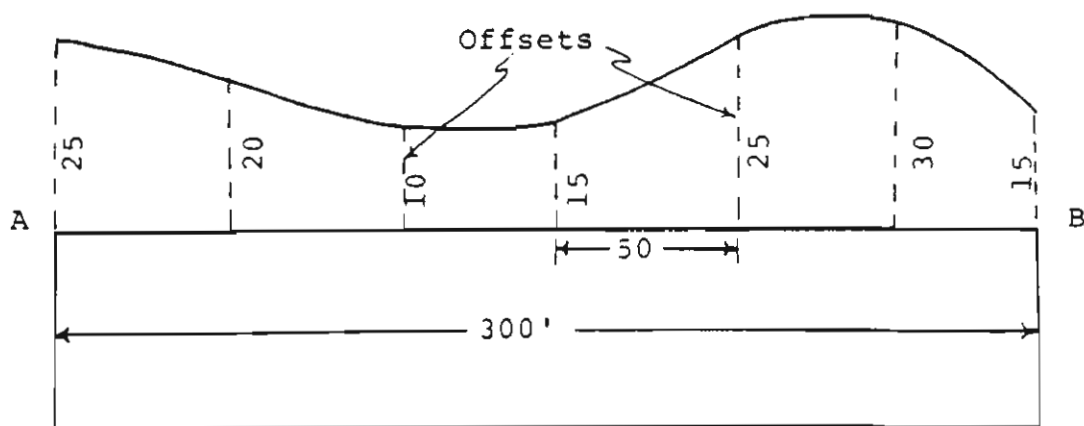

EXAMPLE: Line AB is 300 feet long and the lengths of the offsets are 25, 20, 10, 15, 25, 30 and 15 feet as shown. The uniform spacing between offsets is 50 feet; the sum of the two end offsets $\frac{(25 + 15)}{2} = 20$; then $20 + 20 + 10 + 15 + 25 + 30 = 120$ feet.

Area = $120 \times 50 = 6,000$ sq. ft.

No. Acres = $6,000 \div 43,560 = .13$ acres

Area of the remainder of field is calculated according to its shape.

UNIT III
USING LEVELING AND LAND MEASURING EQUIPMENT

To obtain consistently accurate work when using leveling and measuring equipment the operator must not only know how to set up and operate the various tools but must be capable of visualizing the process as the operations are performed. To avoid omissions in procedure, experienced surveyors develop a specific procedure of performing their work. It is the purpose of this unit to describe procedures for using the tripod level and the steel tape for leveling and measuring operations.

The Tripod Level

Learning how to operate the tripod level is not a difficult task. However, to obtain consistently accurate results the level must be handled, operated and cared for properly. Perhaps the most important part of learning how to use the level is to know the techniques of setting it up properly so that sighting will be accurate. The following steps of procedure should be taken in setting up the tripod level correctly.

Step I

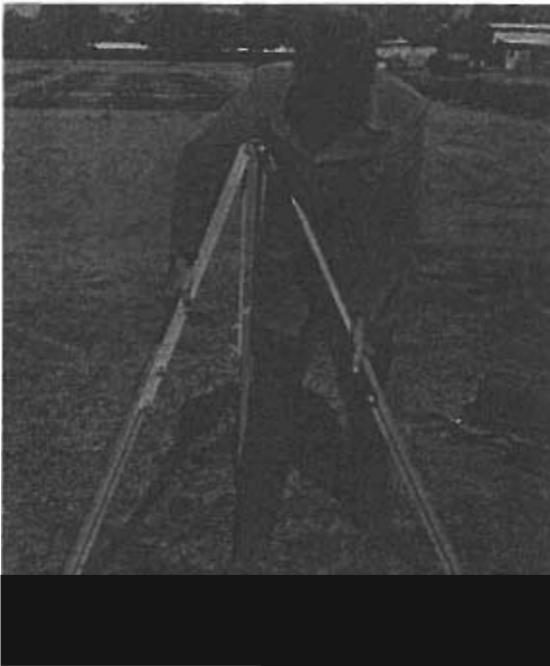

First, set up the tripod and adjust the head to an approximate level setting. This operation reduces the need for large adjustments when leveling the instrument to an accurate setting.

To set up the tripod, loosen the tripod wing nuts to remove friction from the legs, spread the legs 3 to 4 feet apart and push them firmly into the ground. Adjust the legs accordingly to bring the head of the tripod to a rough setting. Estimate the levelness of the head to a level line in the distant horizon and match the head of the tripod to this line. A fence or building may also be used as a guide. If the ground is sloping, place two legs of

the tripod down slope. It may be necessary to move the legs up or down hill to obtain a rough setting of the tripod head. Remove the thread protection cap and place it in the instrument case.

Step II



Remove instrument from its case. Pick up the instrument by the base to prevent damage to the delicate telescope tube.

Step III



Attach instrument to tripod. Hold the instrument in one hand while turning the base with the other hand. Tighten the base snugly with hand -- do not force.

Step IV

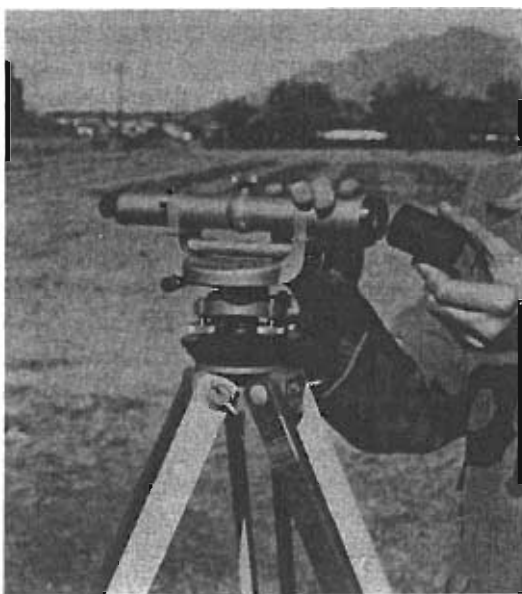

Remove the lens protection cap and place it in the instrument case and attach sunshade to the telescope tube. The sunshade is used to reduce reflection and glare.

Step V



Check the location of the setting. Sight through the instrument to determine whether the level will come within limits of the rod. If not move to a new location. If the rod can be read proceed to Step VI.

Step VI

Level instrument to an accurate setting. Rotate the telescope tube in alignment with two leveling screws. Grasp the two leveling screws between the thumb and forefinger of each hand; rotate the leveling screws by bringing the thumbs of the hand toward or away from one another. The bubble in the level tube will follow the movement direction of the left thumb. (Figures 3-1 and 3-2) Keep the shoes of the four leveling screws pressed firmly on the backing plate but avoid binding. Place the telescope tube over the second set of leveling screws and repeat the leveling operation. Recheck and make changes as necessary through the 360 degree azimuth circle. Caution: Do not overtighten the adjusting screws.

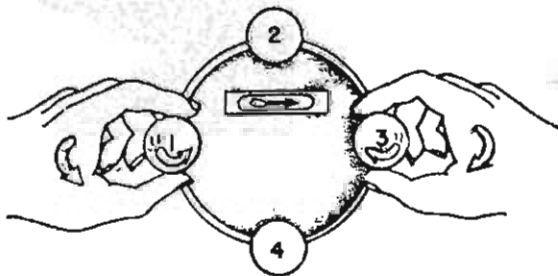

Fig. 3-1. Turning both leveling screws "in" moves the bubble to the right.

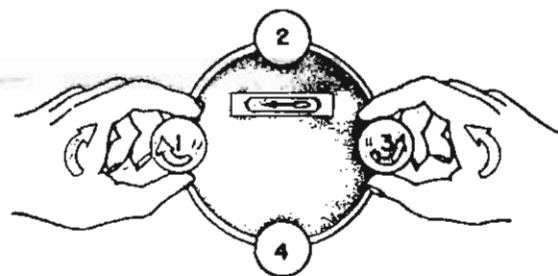

Fig. 3-2. Turning both leveling screws "out" moves the bubble to the left.

Adjust eyepiece and objective focus. Aim the telescope tube at an unmarked object such as the sky and adjust the eyepiece until the cross hairs are in sharp focus. To adjust the objective focus, aim the telescope tube at an object and adjust the objective focus until the object is clearly visible.

Step VII



Testing the Tripod Level for Proper Adjustment:

The leveling instrument can be bumped or jolted out of adjustment. When the line of sight and the bubble of the level are not exactly coordinated, the sightings taken will be incorrect. When this happens it is then necessary to check and if necessary adjust the instrument to insure that the line of sight is level.

The procedure for checking the level for adjustment using the "two peg" test is as follows:

- Step I On a fairly level area, drive two stakes (A & B) into the ground approximately 300 feet apart.
- Step II Set the level in such a position that the eyepiece is approximately one inch or less in front of the rod held on top of Stake A. Level the instrument to where the bubble in the level tube indicates the instrument to be level.
- Step III Take a rod reading on Stake A, sighting through the objective end of the telescope tube. Next, set the rod on top of Stake B and sighting through the eyepiece take a rod reading at Stake B. The difference between the two readings will be the difference in elevation plus or minus the error of adjustment.
- Step IV Move the level to Stake B, set up as before, and take a rod reading on Stake B sighting through the objective end. Sighting through the eyepiece take a sighting on Stake A. As before, the difference between the two sightings is the difference in elevation of Stake A and B plus or minus the error of adjustment.
- Step V The true difference in elevation of points A and B is determined by adding the difference in elevation determined in Step III and IV and dividing by two. This will give a mean of the two results. Knowing the true difference in elevation between the two points and the height of instrument at Stake B, the correct rod reading at Stake A can be computed by subtracting the true difference in elevation from the rod reading at Stake B. This calculation

gives a level sight. If the instrument is out of adjustment the rod reading taken on A from the instrument on Stake B will differ from the calculated reading.

Instrument at A

Rod-reading on A =	4.062
Rod-reading on B =	5.129
Difference in elevation of A and B	<u>1.067</u>

Instrument at B

Rod-reading on B =	5.076
Rod-reading on A =	4.127
Difference in elevation on B and A	<u>0.949</u>

Mean of two differences in elevation =

$$\frac{1.067 + 0.949}{2} = 1.008 \text{ true difference in elevation}$$

Instrument is now 5.076 above B

Rod-reading at A should be $5.076 - 1.008 = 4.068$ to give a level sight.

Amount of adjustment needed

Rod-reading at Stake A from instrument on B	=	4.127
Reading to give level sight	=	4.068
Adjustment necessary		<u>.059</u>

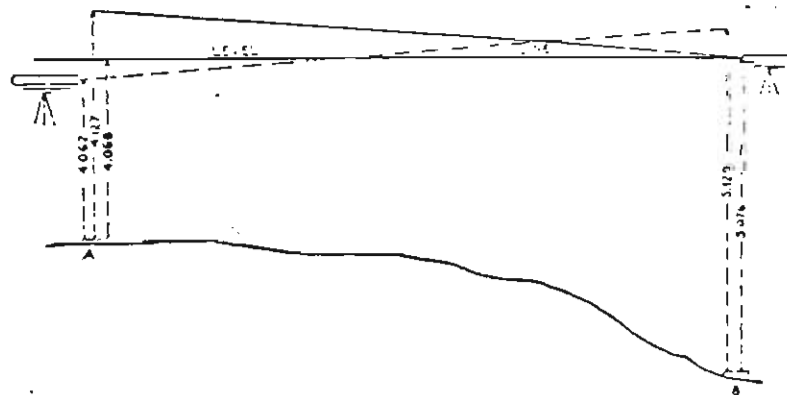

Fig. 3-3. Two Peg Adjustment

Checking the Horizontal Cross Hair:

Checking the horizontal cross hair adjustment can be easily performed while the level is still set up and leveled

at Stake B and sighted at the target on the rod held on Stake A. Be sure that the center of the horizontal cross hair bisects the target; then rotate the level back and forth slightly from side to side. If the ends of the cross hair cut the target in the same place as did the center of the cross hair, it is in adjustment. If the ends of the cross hair do not remain on the spot as did the center, the cross hair should be adjusted. A second and perhaps quicker method of checking the horizontal cross hair is to sight on a building's point. If the cross hairs are not in accurate horizontal adjustment the horizontal cross hair lines will not superimpose on the point as the telescope is turned. Usually, if the cross hairs need adjustment, it is best to have it done by someone experienced in the adjustment and repair of surveying equipment. (See Figure 3-4)

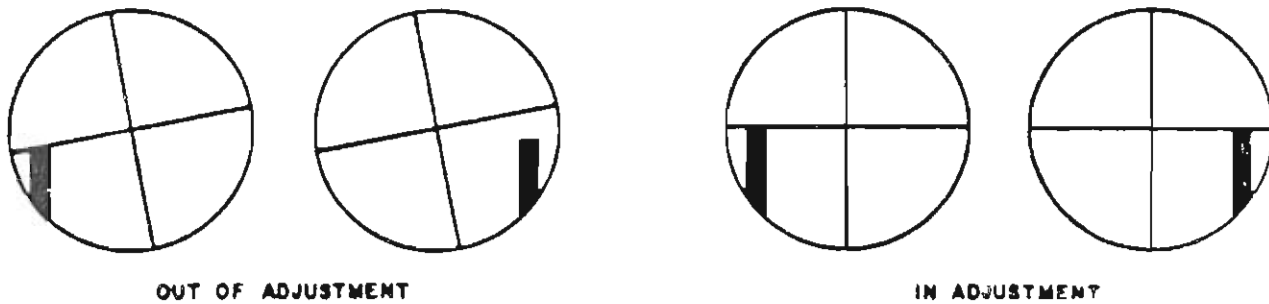

Fig. 3-4. Adjustment of horizontal cross hairs.

The Leveling Rod

Leveling rods are used with a leveling instrument to take and read vertical measurements. Leveling rods are classified either "self-reading" or "target" rods or a combination of the two. Self-reading rods are read directly from the instrument by the instrument man. Target rods utilize a sliding target mounted on the rod. The instrument man instructs the rod man to move the target until the instrument cross hairs, as viewed through the telescope, bisect the target. The rodman then reads the rod. Most leveling rods consist of two or three sections of hardwood 4 to 7 feet in length which permit the rod to be extended to approximately thirteen feet. The rod shown in Figure 3-5 is a three section or San Francisco Rod. The two section leveling rod, which will be discussed in this unit, is also known as the Philadelphia Rod. (See Figure 3-6)

Reading the Leveling Rod:

The following drawings illustrate a rod and target. Major divisions of the rod in feet are shown in large red numbers with the number one starting at the bottom of the rod. Between each foot indicator are nine (9) numbers in black.

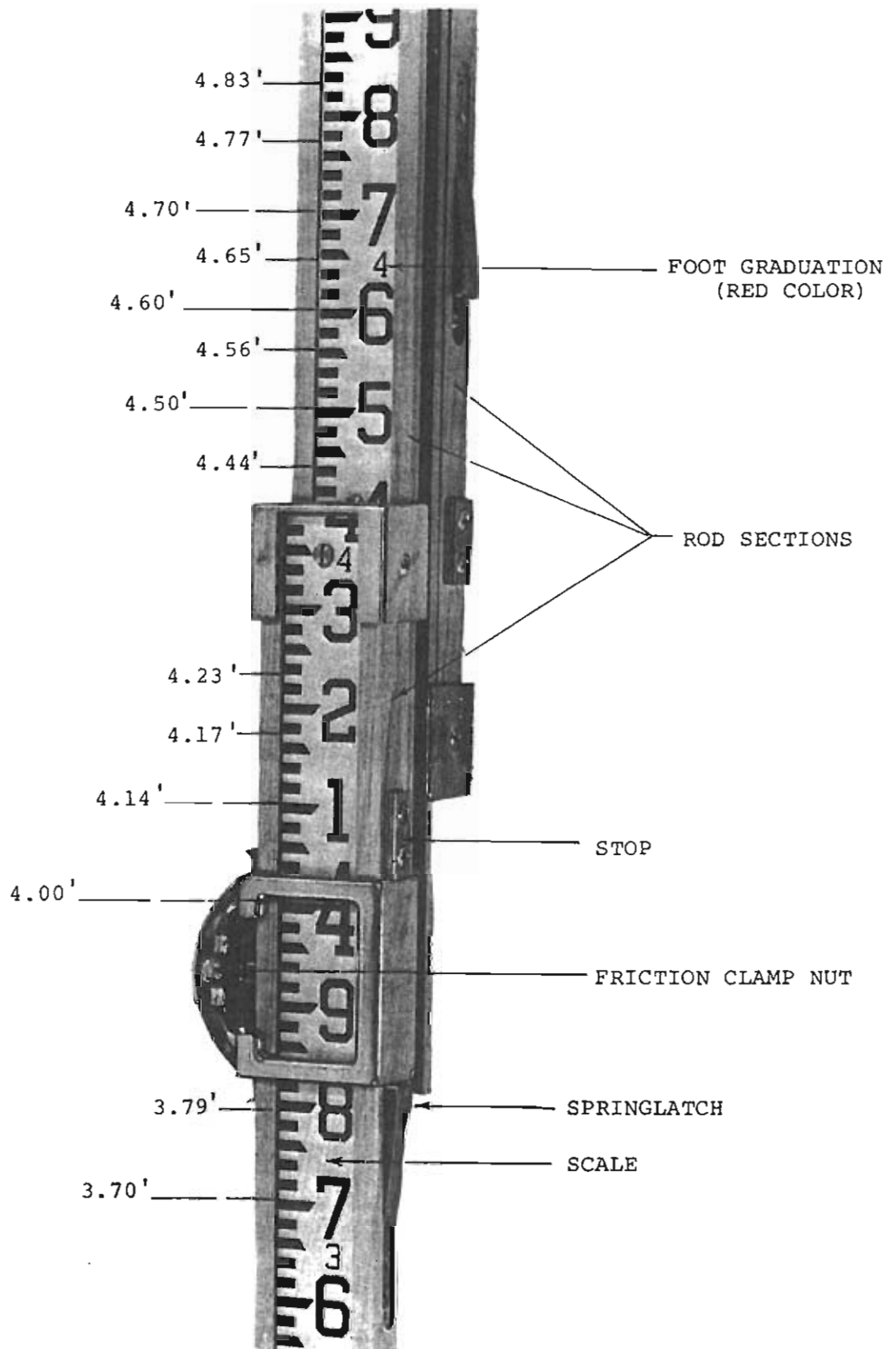

Fig. 3-5. Three section San Francisco Rod
(Courtesy of Lietz)

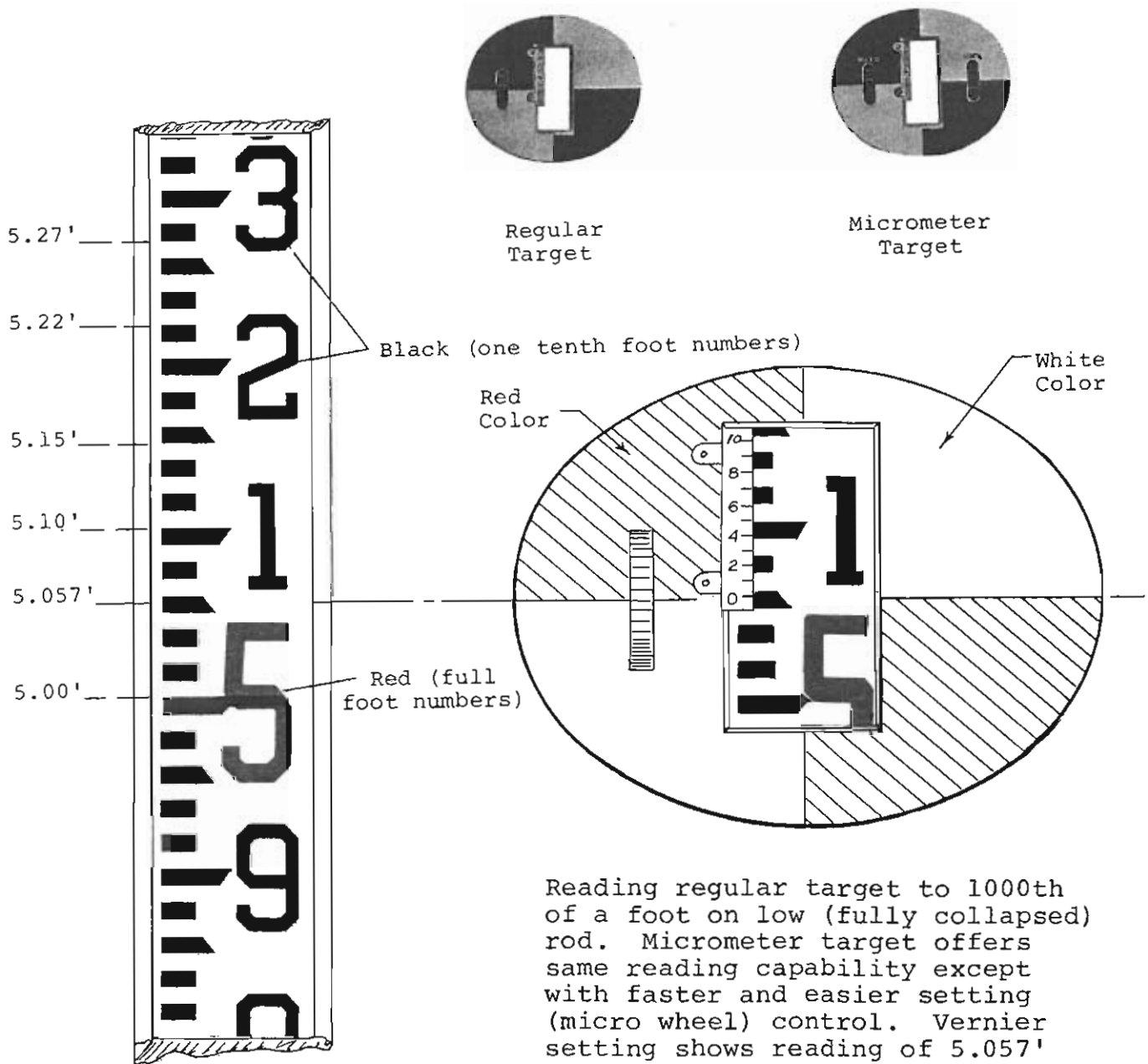

Fig. 3-6. Philadelphia Rod and targets

Opposite each of the numbers is a wide black line to indicate that these points are one tenth (.10) of a foot measurement. Between each of tenth's numbers are four (4) black spaces and five (5) white spaces. Each of the equal width spaces represents one hundredth (.01) foot distance. (Figure 3-6).

Extending the Leveling Rod:

Often times the terrain being traversed will require extending the rod to avoid moving the instrument to a new location. Errors can easily occur should the rodman not extend the rod to its maximum length. Partial extension will destroy the continuity of scale readings when the instrument man is reading the rod. The rodman should continuously check to make sure that the rod clamps are securely and accurately locked.

Using the Target:

A target is useful when operations require (1) determining the land position where the elevation is the same, (2) setting stakes in the soil to the same elevation and (3) when the rodman is accurately reading the rod. In the latter case, a vernier attachment to the target permits readings to 1/1000 of a foot. For readings up to 7.00' the Philadelphia Rod is clamped into the low (fully collapsed) position. The target can then be pre-set or read to 1000th or a foot. To obtain rod readings above 7.00' the clamp has a built-in vernier enabling the user to pre-set or record an elevation (reading to 1000th of a foot). When used this way, the target is accurately affixed at the 7.00' mark - and then read by referral to the reversed scale on the back face of the rod. Thus target readings between 7.00' and 13.00' can be obtained or set. (See Figure 3-6)

Holding the Leveling Rod:

The rodman should hold the rod in a vertical position at all times when it is being used. A good rodman usually stands as straight as possible with the bottom of the rod on the ground directly between the toes of his shoes and slightly in front of them. The rod is then "plumbed" by lining it up with the rodman's body. The hands are positioned with the fingers up and palms on either side of the rod to prevent any interference in reading the rod.

Field Signals

Usually the instrument man and the rodman are far enough apart that a system of signals may be helpful. The signals used may be varied to fit the situation, but all signals used should be well understood in advance by all members of the party. Here are some suggested signals:

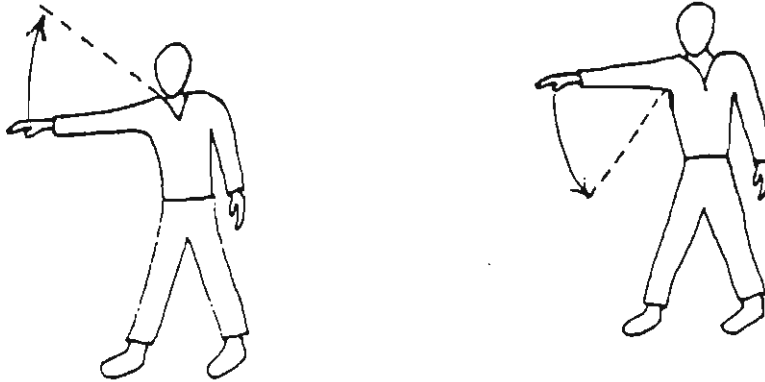

Fig. 3-7

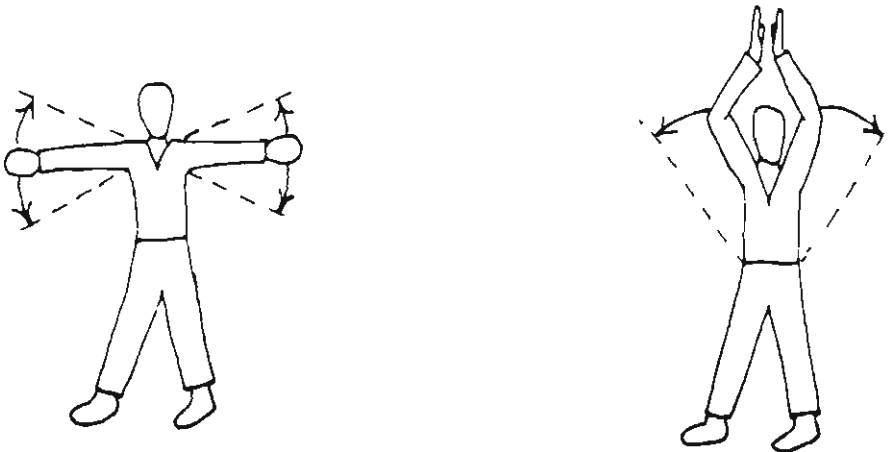

Fig. 3-8

Fig. 3-9

"Up or "Down" - Usually used by the instrument man to request the rodman to raise or lower the target on the rod or to move up or down slope in certain work with contours. The instrument man motions to the rodman by raising his arm above his shoulder for an upward motion and dropping his arm below his waist for a downward motion. A slow motion indicates that the move should be a considerable distance. A quick motion is for a short distance. (Figure 3-7)

"Alright" - The instrument man extends both hands horizontally and moves them up and down. At close range he may simply show the palms of both hands. (Figure 3-8)

"Plumb the Rod" - (Hold the rod exactly upright.) Extend arms full length above head and move them slowly in the direction required as shown by the vertical cross hair.

If the rod is not being held plumb in a direction perpendicular to the line of sight, the instrument man can see that it does not line up with the vertical cross hair of his telescope. However, when the rod is out-of-plumb in the same plane as the line of sight, the instrument man will signal the rodman to move the top of the rod slowly back and forth in a plane toward or away from the instrument. The reading will be higher if the top of the rod is forward or rearward of plumb position. Thus, when the rod is waved forward and backward through the plumb position, the correct reading is the smallest reading observed. (Figure 3-9)

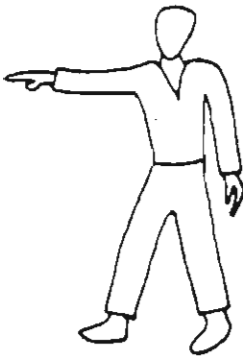

Fig. 3-10

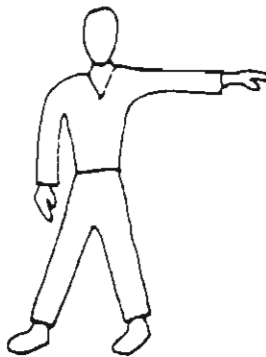

Fig. 3-11

"Move to Right or Left" - Extend the hand in the direction wanted. (Figure 3-10)

"Take a Turning Point" - The arm is swung slowly in a circle above the head. (Figure 3-11)

Leveling Terms and Field Notes

Of all the operations accomplished by a leveling party, the most important is note keeping. It is obvious that no matter how carefully the leveling operation is done or how experienced the leveling party may be, all is rendered valueless if the field notes are incomplete or unclear. Leveling terms assist the note keeper in keeping legible notes. It is

the purpose of the following discussion to describe the standard method of logging data which at a later date can be clearly understood by the original leveling party or others knowledgeable in their interpretation.

Leveling Terms:

Bench Mark - (Abbreviated BM). A permanent reference point for which the elevation is known or assumed. For agricultural work a concrete well curb, the corner of a road culvert, or other convenient and relatively permanent point may be chosen. It is convenient to assign it an elevation, such as 100 feet. All measurements are then relative to this point of reference.

Backsight - (Abbreviated BS). This is a rod reading taken on a point whose elevation is known. A backsight reading is the vertical height of the level line of sight above the known elevation. The elevation of the line of sight can then be computed.

Height of Instrument - (Abbreviated HI). This is the elevation of the level line of sight. It is obtained by adding the backsight reading to the known elevation of the point upon which the backsight is taken.

Foresight - (Abbreviated FS). It is a reading taken on a new point to determine its elevation. The foresight reading is the vertical height of the new point in relation to the level line of sight. The elevation of the new point can then be computed when the height of instrument is known.

Turning Point - (Abbreviated TP). This is a temporary point of known elevation. When it becomes necessary to move the instrument to a new location in order to read the rod, the last rod setting is held at the last point for which the elevation has been determined. This becomes a Turning Point. The turning point therefore serves as a reference for calculating a new height of instrument when the instrument is moved to a more advantageous location for continuing the survey.

Taking Field Notes:

Surveying "field notes" are a record of sightings made on the rod (rod reading). If the notes are incomplete, incorrect or destroyed, much or all of the time spent in making accurate measurements may be lost. A field book containing information gathered over a period of weeks is worth thousands of dollars, assuming that it cost \$150-\$200 per day to maintain a party of four men in the field.

Field notes maintained by the instrument man should contain a complete record of all measurements made during the progress of the day's work on the survey. Four types of notes are kept: (a) sketches, (b) tabulations, (c) description, and (d) combination of these. Care should be taken in lettering the field notes. Field notes should be clear and convey only one correct interpretation. Field notes are never transferred from one book to another. Make all notes as legible as possible in the field book used during the survey. Any errors made in the field book are never erased, but should have a line drawn through them, with the correction notes.

Arrangement of Notes:

The first page of the notebook is the index. Figure 3-12 is an example of how the index page should be completed:

Each double page thereafter is numbered one through the number of pages needed. The left side of the double page at top center should describe the type of exercise attempted. Below this, the information obtained during the survey and all calculations is presented. The right side of the double page in the upper right hand corner should list the page number. On the first line, upper left hand corner, should be the date, below this, the weather and temperature. In the right hand corner below the page number, should be the crew members' names. Below the temperature on the left side of the page should be a list of the equipment used, location of the survey, and a map of the area surveyed. The direction "north" should be indicated on the map. (Figure 3-13)

INDEX					Page
PACING					1
PROFILE	LEVELING				2
DIFFERENTIAL LEVELING					3
CUTS & FILLS					4

The Steel Tape

In agricultural production practices acreages need to be known for government acreage allotments and per acre cost calculations. Knowing the crop acreage is also useful when purchasing fertilizer, pesticides, etc. Many agriculturalists use the steel

Fig. 3-12

tape to determine acreage. This is probably the most accurate method of measuring horizontal distances.

PACING	May 1, 1973 Clear 110°	PAGE 1
<p>A-B 200 paces B-C 400 paces</p> <p>Pace = 2.94'</p> <p>2.94 X 400=1176.0'</p> <p>2.94 X 200=588.0'</p> <p>$\frac{1176 \times 588}{43,560 \text{ sq ft/acre}} = 15.82 \text{ A}$</p>	<p>Equip. JONES 100' tape SMITH DOE</p> <p>Location: NW corner of feedlot</p>	

Fig. 3-13

Chaining (Taping) Procedure:

The chaining operation using a steel tape should follow a standard procedure to reduce potential errors. First the head chainman goes forward and sets the range pole for "lining-in" purposes. Meanwhile, the rear chainman "throws" the tape by laying it out in the general direction of the line to be measured, being careful that it is not looped or twisted. The head chainman then takes the zero marked end of the tape and moves forward pulling the tape toward the first range pole. When the 100 foot marked end of the tape nears the first pin, the rear chainman calls out "chain". At this signal, the head chainman halts and quickly places himself in a straight line with the range pole aided by left or right signals from the rear chainman.

As soon as the tape has been placed on line, the rear chainman holds the 100 ft. mark exactly even with the pin. The head chainman takes his position just to the left of the line (not on the line), kneels, and applies approximately 10-12 pounds of tension to the tape with his left arm bearing against his leg. His right hand is then free to place the pin on line and at the zero mark of the tape. When the head chainman sets his pin, he should be assured that the rear chainman is holding his end of the tape accurately on the mark. Also the rear chainman must not pull his pin until the head chainman has finished setting his pin. A system of communication is needed. Therefore, before setting his pin, the head chainman waits for the signal "right here" from the rear chainman. As soon as he has set the pin, the head chainman also calls out "right here". This is also the signal for the rear chainman to pull his pin. It is important that the signals be carefully coordinated.

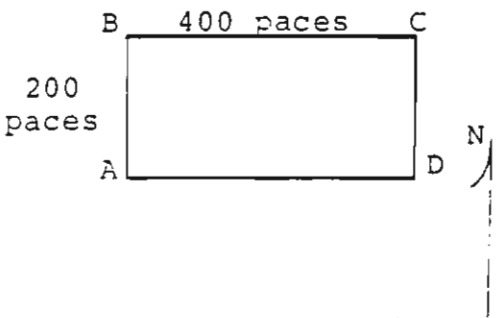
At the initial starting point (generally marked by a transit stake) the head chainman holds a ring containing eleven pins. The head chainman sets the first pin adjacent to the stake. He then proceeds with the zero end and lays out 100 feet of tape in the direction to be measured and places the second pin at the 0 ft. mark of the properly tensioned tape. On command the rear chainman pulls the first pin to indicate that one tape length has been measured. When the head chainman sets the third pin, the rear chainman pulls his second pin. This confirms that two tape lengths have been measured. When the head chainman sets his eleventh or last pin, he calls out "tally". The rear chainman now has ten pins which he brings forward so that the chaining process can be continued. The number of "tallies" recorded will be the number of thousands of feet which have been measured.

If the end of the line being measured is a previously fixed point, the last measurement will nearly always be a fractional tape length. It is here that mistakes in chaining most frequently occur. To avoid confusion the following systematic procedure is recommended when using a tape which has an additional foot marked in tenths extending beyond the zero end. (See Figure 2-14b)

When the end of the land distance to be measured is reached, the head chainman halts and the rear chainman moves to the last pin where he quickly adjusts the tape so that an even foot mark is aligned with the pin. This is done so that the head chainman's end of the tape will fall within the section of the tape which is subdivided into tenths. Tension is then applied, and the head chainman reads the number of tenths, estimating hundredths, if necessary, which is in alignment with the pin. At the same time the rear chainman identifies the number of the foot mark which is opposite the pin. The tenths which the head chainman reads is added to the number the rear chainman reads, to obtain the measured

distance. For example, the head chainman reads 0.28 ft. as that part of the tape which extends beyond the 0 ft. mark and the pin alignment point. Because the rear chainman had previously set the tape at the 35 ft. graduation, the head chainman then calls out "add twenty-eight hundredths"; the rear chainman calls out "thirty-five" and they both make the addition mentally and check each other on the result, which is determined to be 35.28 ft. If, in addition, the rear chainman should carry seven (7) pins on his ring, (he does not count the one in the ground), the total distance measured would be 735.28 feet.

If the tape is marked as illustrated in Figure 2-14b, the tenth reading is subtracted from the rear chainman's reading. In the above illustration, assume the head chainman reads 0.28 ft. This figure would be subtracted from 35 ft. to obtain a measured distance of 34.72 ft.

If the chaining is done on a hard surface, such as a sidewalk, steel rail, or pavement, the position of the end of the tape is marked with a piece of colored lumber crayon or kiel. The number of the tape length is recorded beside the mark as a means of keeping the count of tape lengths measured. To avoid mistakes, the rear chainman calls out the number of his mark just before the head chainman records the next number.

Taping on Sloping Ground:

The procedure for measuring with a steel tape on sloping ground is the same as on level land areas except that after the chain has been laid out its entire length by the head chainman, he returns to a point selected by the rear chainman. When moving up hill, the rear chainman, with the aid of the hand level or by estimation, will hold the chain about chest high at a point along the chain. The head chainman will hold the chain at this point on the ground surface. With the aid of a plumb bob, the rear chainman will hold his end of the chain directly over the starting points. (Figure 3-14) If the head chainman is going downhill the procedure is reversed.

Pins are used at each breaking point of the chain. However, the pins are not counted the same as on level ground. Instead, a record is kept of each distance taped until the 100 foot point cumulative is reached, then the 100 foot interval is recorded.

When distances are measured on the ground surfaces which are sloping in comparison to using the level tape technique, a correction must be added to the surface distance to secure the true horizontal distance. For each 100 ft. of a known percent slope a correction of $\frac{s^2}{200}$ / 100 ft. is added

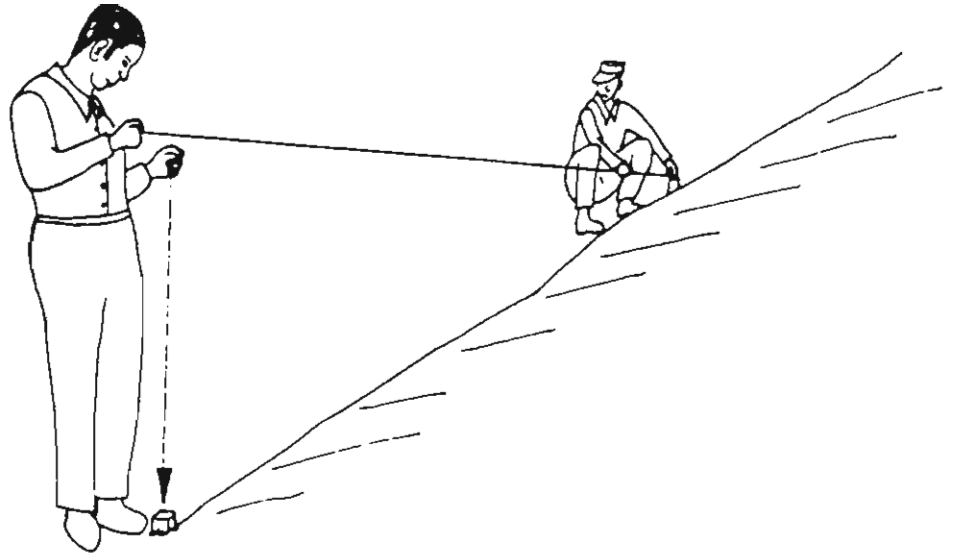

Fig. 3-14. Chaining on Sloping Ground - The rear chainman holds the tape about chest high and with the use of a plumb bob will hold the tape directly over the starting point.

(S = percent of slope). For example, if the slope were 10 percent and the distance measured was 300 ft., the correction would be computed as follows:

$$\frac{s^2}{200} / 100' = \frac{(10)^2}{200} \times \frac{300}{100} = \frac{100}{200} \times \frac{300}{100} = 1.33 \text{ ft.}$$

$$300 \text{ ft.} + 1.33 \text{ ft.} = 301.33 \text{ ft.} = \text{correct lineal distance measured}$$

A set of field notes for breaking chain is illustrated in Figure 3-15.

Errors in Measurement:

Errors in measurement include:

1. Tape not pulled tight enough.
2. Tape not in proper alignment.
3. Pins not carefully placed at proper marks on tape.
4. Mistakes in counting pins.
5. Mistakes in determining number of feet less than 100 feet. This happens when using the fractional length at the end of the tape.
6. Plumb bob not used when measuring on a slope.
7. Wrong points on the tape used for zero or the 100 foot mark.
8. Reading or recording the wrong numbers.

JUNE 1, 1973
 CLOUDY 85°

PAGE 1

CHAINING

STATION	FEET	TENTH
1	62	00
2	68	00
3	26	00
4	100	00
5	27	72
TOTAL	283	72

EQUIPMENT:
 HC - JONES
 RC - SMITH

1/00 Chaining Pins
 2 ea. Plumb Bobs
 Range Pole
 Field Notebook

Location: NE 1/4, NE 1/4,
 Section 8

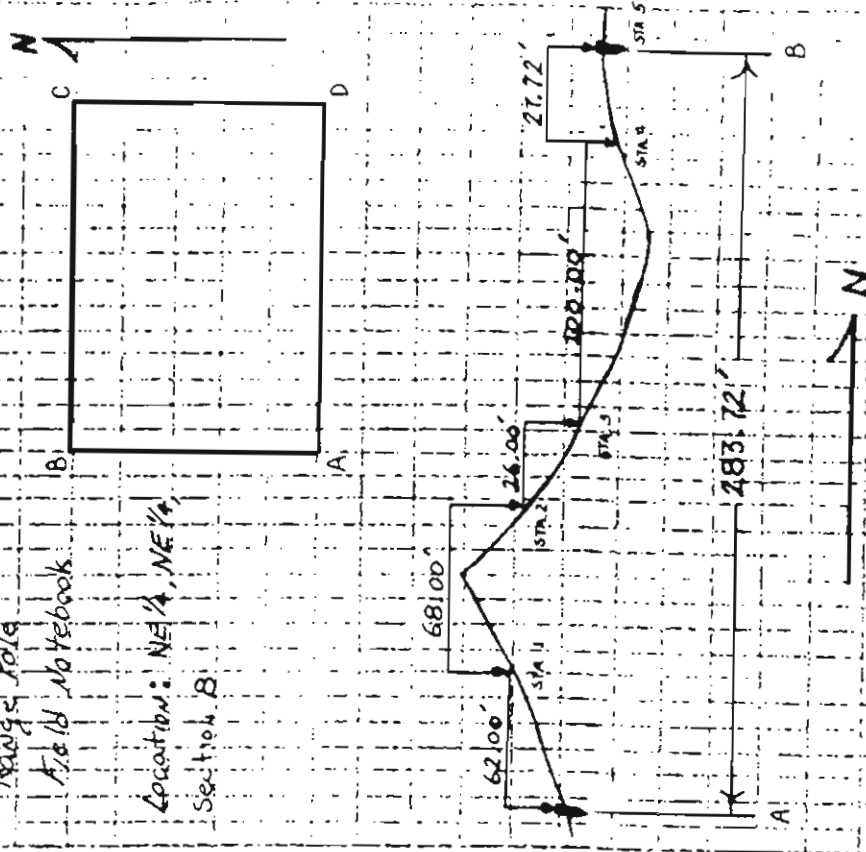

Fig. 3-15. Field Notes for Breaking Chain

Measuring Horizontal Distances With a Level

The telescope tube of some levels contain 3 horizontal cross hairs. (Figure 3-16) The top and bottom cross hairs are called stadia hairs and may be used to measure horizontal distances. The stadia hairs are usually spaced so that when the stadia hairs align with a one foot interval between them the rod is being held 100 feet from the tube. (Figure 3-17)

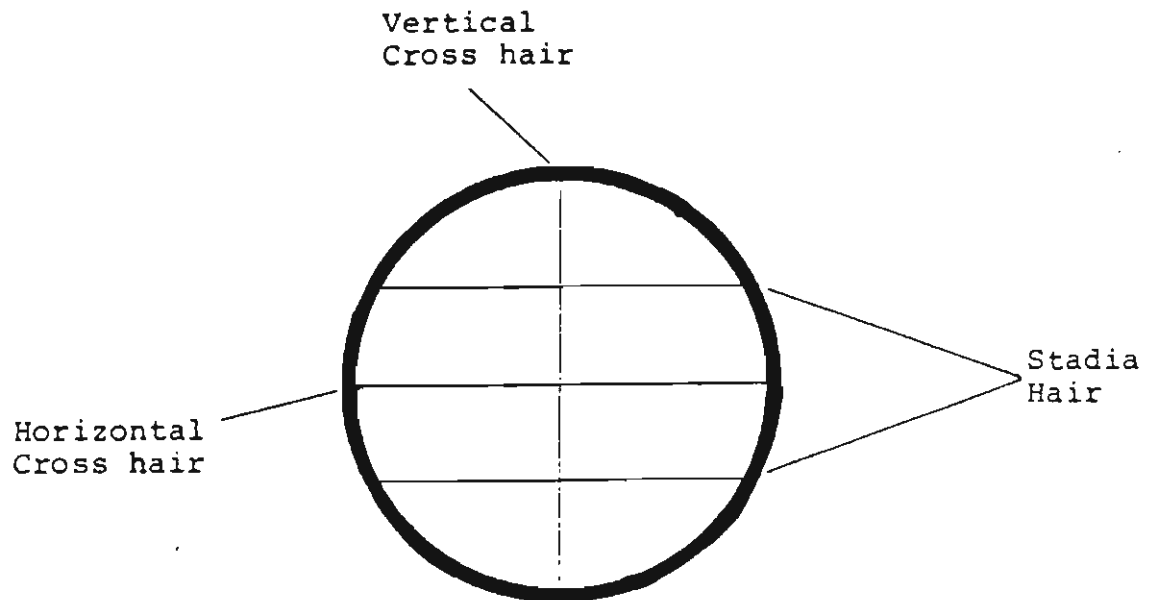

Fig. 3-16. Looking through the telescope tube you will see three horizontal cross hairs.

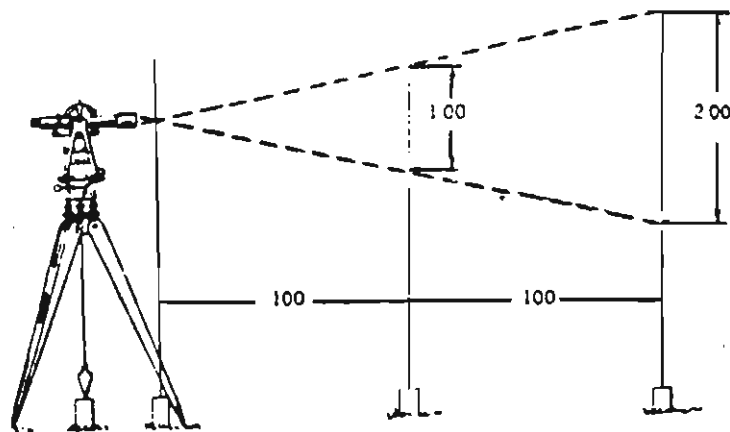

Fig. 3-17. Each foot intercepted on the rod represents a distance of 100 feet.

Figure 3-18 further illustrates the measurement of distance using stadia. The instrument man reads 1.89 ft. with the top stadia hair and 1.21 ft. with the bottom stadia hair. The difference in readings times 100 equals a horizontal distance of 68 feet.

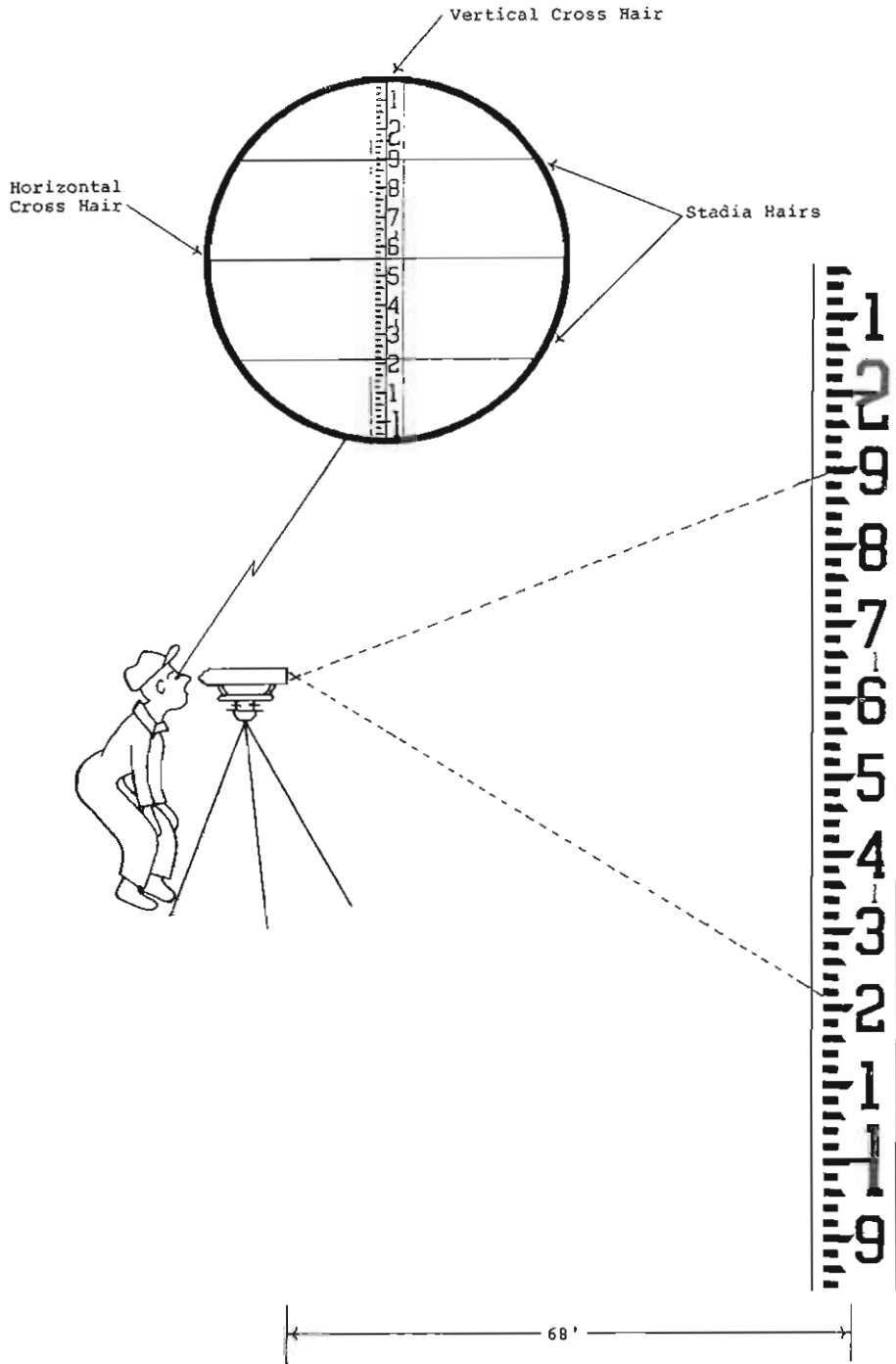

Fig. 3-18. Measuring horizontal distances using the stadia.

Land Measurement by Use of Aerial Maps

With the use of aerial maps similar to the one in Figure 3-19 agriculturalists can measure land distances and determine acreages. Mechanical, direct reading map measures simplify measurements of straight or curved lines on aerial maps. (See Figure 3-20) The map measurer is simple to use. The indicator is set at zero and the line to be measured is traced with the tracing wheel as the instrument is lightly hand-held like a pencil. The hands of the instrument will indicate the length of the line in feet and inches (1/8 inch or 1/10 inch). The map measurer is self correcting. The length of an incorrectly traced line is subtracted simply by "back tracing".

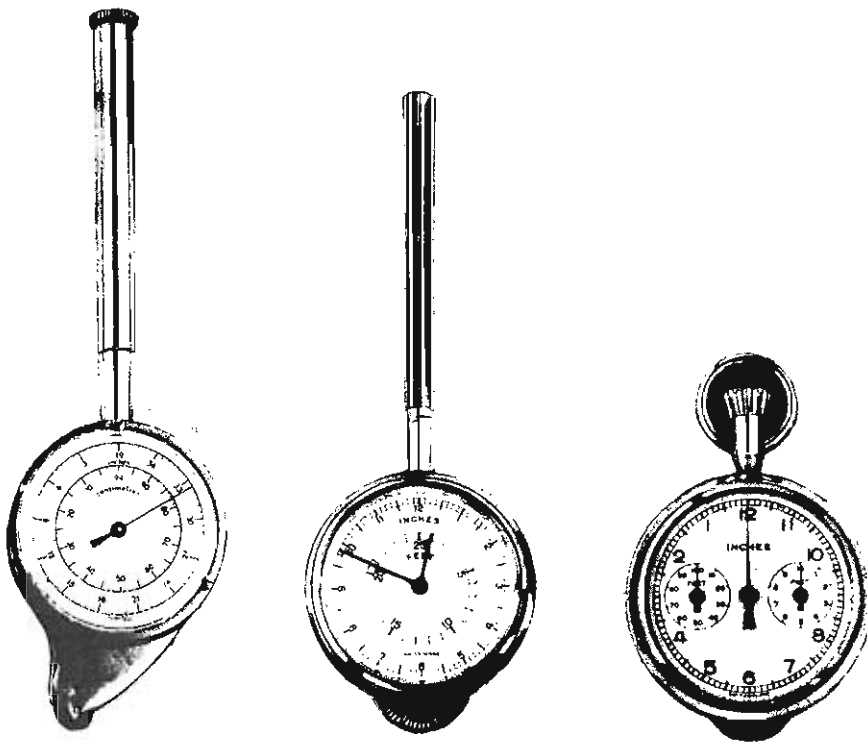

Fig. 3-20. A wide variety of map measurers are available, offering a broad range of measuring units.

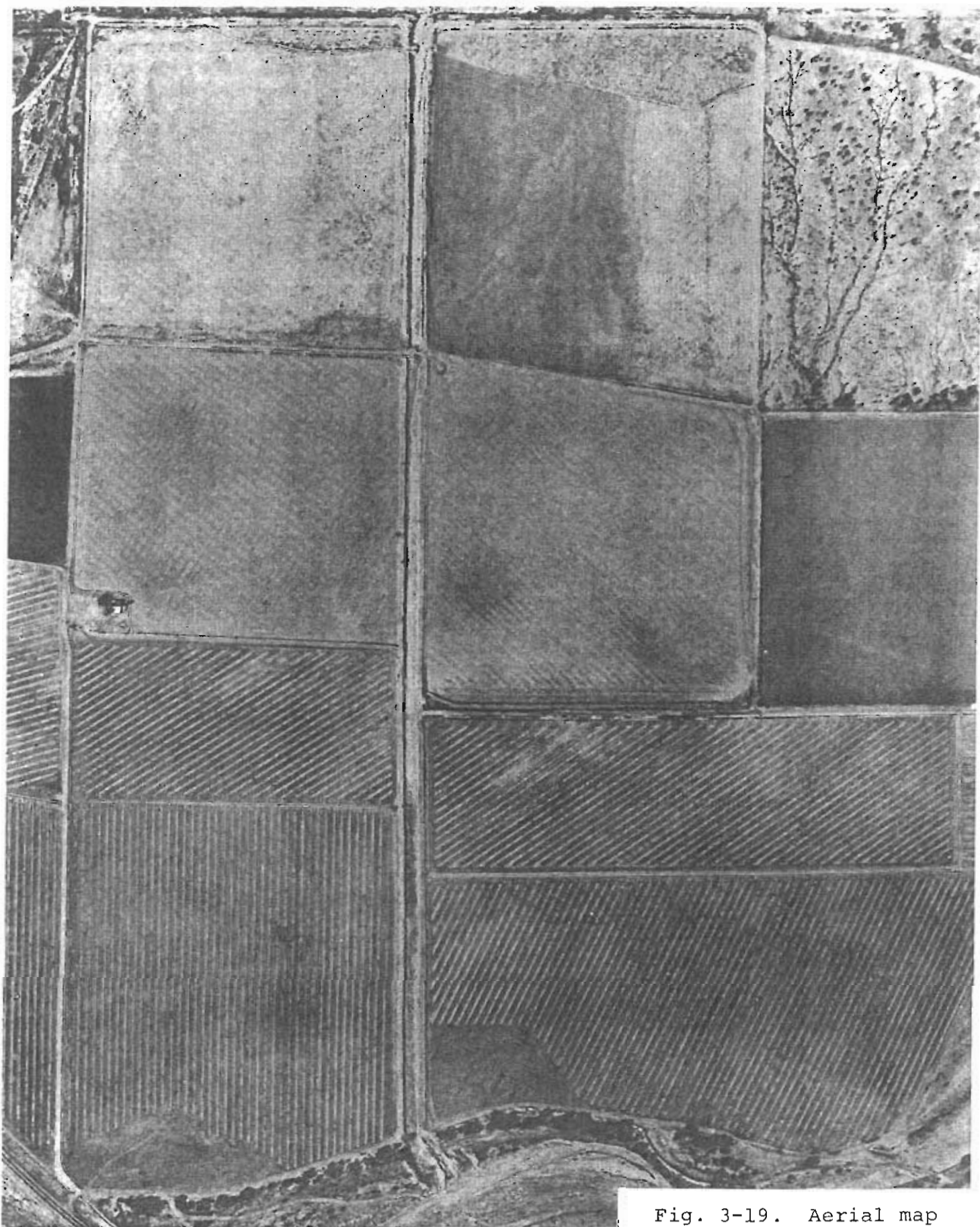

Fig. 3-19. Aerial map
of an agricultural area.
Scale: 1 inch = 400 feet

If a map measurer is not available agriculturalists can determine distances on aerial maps with the use of a sheet of paper and an engineer's scale. To do this, lay the edge of the paper on the map next to the line to be measured. If the line is straight, mark the beginning and ending of the line on the edge of the paper. Using the correct "scale" on the engineer's scale determine the distance of the measured line. It should be noted here that the "scale" used on the engineer's scale should coincide with that of the aerial map. To measure a curved line the curve should be broken into short straight lines as shown in Figure 3-21.

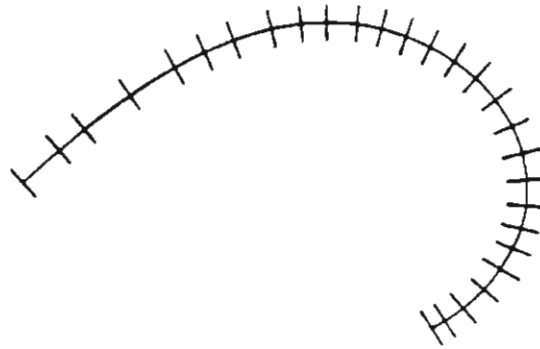

Fig. 3-21. To measure the length of a curved line it must be broken into many small straight lines.

UNIT IV
LEVELING OPERATIONS

The basic function of the tripod level is to provide the operator of the instrument with a level line of sight in a 360 degree horizontal plane. It is from this line of sight specific elevation of land surfaces can be determined. A wide variety of agricultural related land use tasks require that elevation or changes in elevation be known before production or construction activities can be successfully accomplished. It is the purpose of this unit to describe the process and procedures to perform several commonly used leveling operations.

Differential Leveling

Differential leveling is the process of determining the difference in elevation between points. The starting point may be an official bench mark elevation or it may be a point to which an arbitrary value of elevation is assigned. Figure 4-1 illustrates a typical differential level. It makes use of an assumed bench mark with an arbitrarily assigned elevation of 100.00 feet. The object is to determine the elevation of a new point.

Procedure:

The procedure used to accomplish the differential level illustrated in Figure 4-1 is as follows:

1. The instrument man notes that the elevation of the bench mark is established at 100.00 feet.
2. The instrument man sets up and levels the instrument a suitable distance away from the bench mark in the direction toward the new point (Point A). Sighting distance should not be so great as to make it impossible to read the rod accurately. Maximum distance for most levels and for good accuracy is 150 to 200 feet. Longer shots may be taken depending upon the degree of accuracy required.
3. The instrument man makes a backsight reading of 3.60 feet on the rod which is held plumb on the bench mark by the rodman. After taking the reading, the instrument man checks the bubble again to assure himself that it remained centered while he was taking the reading.
4. The reading is entered in his notes in the BS column. To obtain the height of instrument, (HI) the BS reading is added to the bench mark elevation of

100.0 feet. He then enters the value of 103.60 feet in the HI column. He gives the "all right" signal which the rodman recognizes as his cue to move to a new point along the route of survey.

5. The rodman moves the rod toward Point A, the maximum distance limited by the accuracy required and the change in elevation limits due to rod length. He places the rod on a solid spot on the ground making sure that the front face of the rod is plainly visible to the instrument man.
6. The instrument man aligns the telescope toward the rod, focuses and checks to see that the level bubble is centered. He takes a foresight reading of 2.10 feet on the rod and rechecks the level bubble. Entering the reading in his notes he subtracts 2.10 feet from the height of instrument, and obtains an elevation of 101.50 feet for the first rod position which is identified as TP_1 . In differential leveling, the rodman must remember that each new setting of the rod will be a turning point and the signal....."take a turning point", is unnecessary.
7. The rodman holds the rod on TP_1 while the instrument man makes a new setup in the direction of Point A and takes a backsight of TP_1 to get the new height of instrument.
8. Steps 2 through 7 are repeated until Point A is reached and its elevation relative to the bench mark is obtained. The experienced instrument man usually will not make his calculations in the field, as described above. He will have his note keeping procedure well enough organized that he can spend his field time taking readings and entering them properly in his notes. The calculations can then be made at any later time. For the beginner, it is advised that he make the calculations as he goes comparing each new height of instrument and elevation against his own estimate of what it should be. This procedure can be very helpful in avoiding needless mistakes such as reading the wrong foot mark on the rod. It also helps all members of the party to form a visual image of their immediate progress and accomplishments.

Field Notes for Differential Leveling:

It is suggested that the field notes for leveling of this type be kept in five columns. Figure 4-2 shows a set of notes kept in a manner that has been found to help the beginner visualize his procedure and catch errors in entering notes. The typewritten figures are readings taken in the

field. The handwritten figures are computations made from the readings. A plus sign (+) is entered in the heading of the BS column because BACK SIGHT IS ALWAYS ADDED TO ELEVATION TO FIND HEIGHT OF INSTRUMENT. A negative sign (-) appears in the FS column because THE FS IS ALWAYS SUBTRACTED FROM H.I. TO FIND ELEVATION.

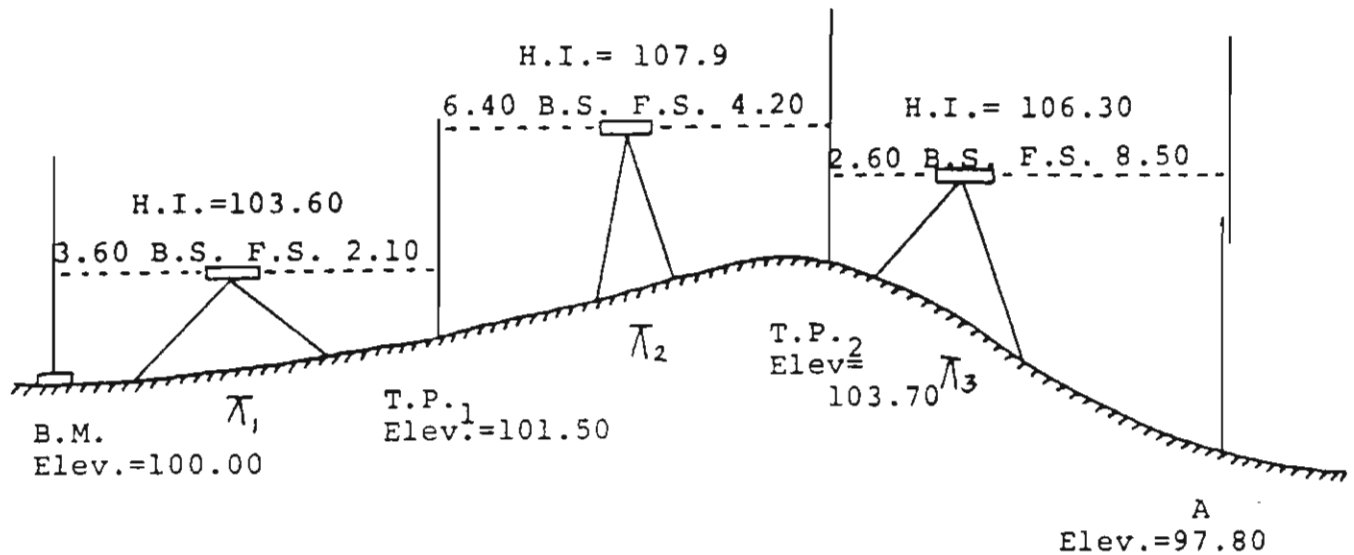

Fig. 4-1. Differential Level

STA.	B.S. (+)	H.I.	F.S. (-)	ELEV.	REMARKS
BM	3.60			100.00	
A ₁		103.60			
TP ₁	6.40		2.10	101.50	
A ₂		107.90			
TP ₂	2.60		4.20	103.70	
A ₃		106.30			
A			8.50	97.80	

Fig. 4-2. Field notes for Differential Leveling of Figure 4-1.

Go back through the previously described procedure and fit it to the set of notes in Figure 4-2. Take particular note of the following:

Since the first BS is taken on the BM, the reading (3.60), is entered on the BM line, BS column. The next line is identified with the symbol λ_1 to indicate instrument height (103.60) set-up number one. Since the next sight is a fore-sight on TP₁, it is entered on a new line labeled TP₁ and in the FS column (2.10). When the elevation of TP₁ is calculated, it is also entered on this same line (101.50). The next sight after the instrument is moved is a BS taken on TP₁, so that reading is also entered on the line, TP₁ - in the BS column (6.40). From here on the notes repeat in successive steps until the job is completed. When a separate line is used for each HI, then a properly entered set of notes follows a pattern on the page represented by the arrows in Figure 4-2. It is often advisable to use the notebook sheet opposite the notes for a rough map of the route and for remarks to help recall the work completed for future reference.

After some experience is gained in keeping notes, it may be desirable to eliminate the extra line used for the height of instrument. A condensed set of notes of the previous leveling operation appears in Figure 4-3.

STA.	B.S. (+)	H.I.	F.S. (-)	ELEV.
BM	3.60	103.60		100.00
TP ₁	6.40	107.90	2.10	101.50
TP ₂	2.60	106.30	4.20	103.70
A			8.50	97.80

Fig. 4-3. Condensed form of notes for differential leveling.

Checking the Calculations:

It may be noted from Figure 4-3 that the difference in elevation between the first and the last point is equal to the sum of all the backsights minus the sum of all the foresights. If the result is negative (the sum of the foresight is the greater) then the final point is lower than the beginning elevation. This procedure may be used as a check on the accuracy of the arithmetic when the longer forms of notes are employed.

Profile Leveling

Profile leveling is the process of determining the elevation of a series of points along a given line. If for example, the cross-section profile of a drainage ditch were to be plotted, the elevation might be obtained at 50 foot intervals along the route. Profile leveling is essential to layout and constructing drains, roads, dams, waterways, and similar structures.

Procedure:

The procedure for profile leveling is very similar to that for differential leveling. The principle difference is that each point upon which a reading is taken is not called a turning point (TP) but a station, and exact distances between points are recorded. The method of recording distances is to identify the successive 100 foot intervals. For example, 0+00 indicates the starting point; 1+00 for 100 feet, 2+00 for 200 feet, etc. Intermediate points such as 150 feet from the starting points are recorded as 1+50; the distance of 235 feet is recorded as 2+35. In addition to the regular intervals, readings are taken at each sharp change in land surface and the distance noted in the conventional manner.

To survey for profile, the area in question is first "stationed", i.e., marked off at intervals of 100 or 50 feet depending upon the job requirements. The level is set up and a backsight taken on a bench mark to establish the height of instrument. Foresights are then taken on as many station points on the line convenient to the position of the instrument.

When it is necessary to move the level to a new position in order to take readings on stations ahead, a turning point is selected and its elevation determined. The turning point may or may not be a station on the line depending upon the choice of the party chief. The level is then taken forward and the new height of instrument determined by taking a backsight on the turning point. This procedure is repeated until the end of the line is reached.

A line of levels should be checked when possible by connecting with some reliable bench mark. If bench marks are available along the line of levels, they should be used as turning points or at least to check readings. When sighting on such points, the reading taken on the bench mark is really a foresight since its elevation will be determined from the height of instrument.

It is a good plan to select turning points that are permanent enough to be used should more than one profile level be required of the area.

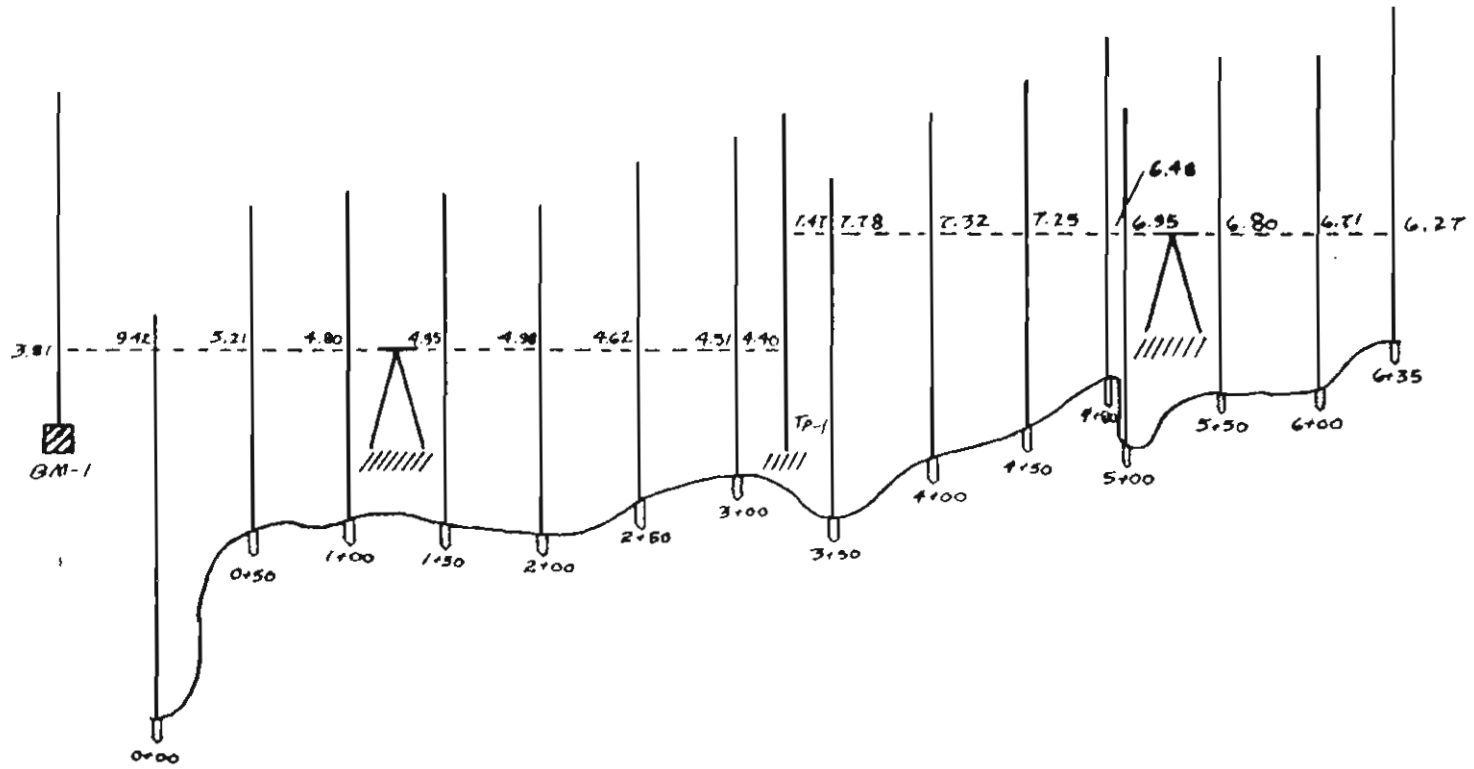

Fig. 4-4. Profile Leveling Operation

PROFILE LEVELING
FOR DRAIN TILE ON R. SMITH FARM

August 12, 1973
Hot, Clear, Calm

R. BROWN \times
K. GREEN ϕ

STATION	BS	HI	FS	ELEV.
BM-1	3.81			100.00
		103.81		
0+00			9.42	94.39
0+50			5.21	98.60
1+00			4.80	99.01
1+50			4.95	98.86
2+00			4.98	98.83
2+50			4.62	99.19
3+00			4.51	99.30
TP-1	7.47		4.40	99.41
		106.88		
3+50			7.78	99.10
4+00			7.32	99.56
4+50			7.25	99.63
4+80			6.48	100.10
5+00			6.95	99.83
5+50			6.80	100.08
6+00			6.71	100.17
6+35			6.27	100.61
TP-2			6.81	100.07
		107.38		
BM-1			7.39	99.99
		ERROR = 0.01'		

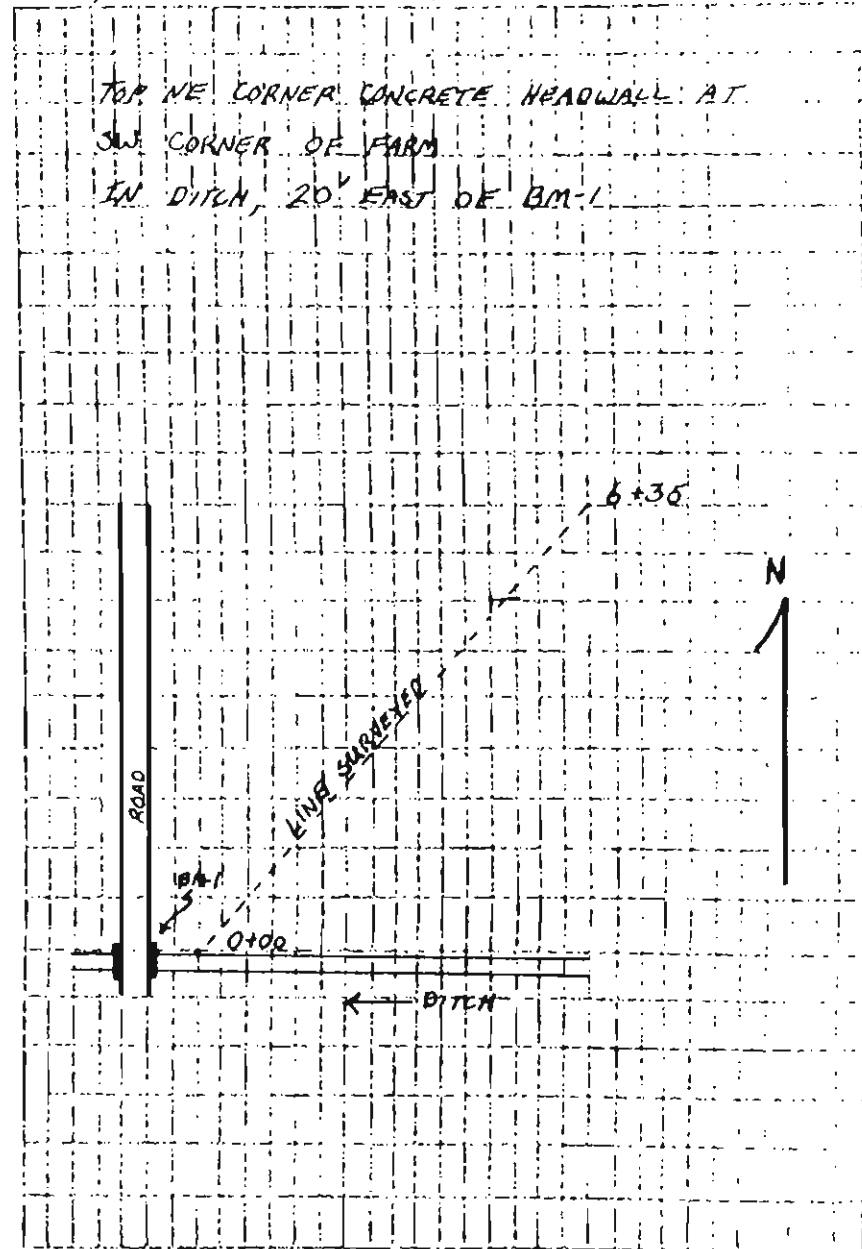

Fig. 4-5. Field Notes for Profile Leveling

Figures 4-4 and 4-5 show a profile leveling operation and the field notes for a tile drain over a 635 foot course. Readings were taken at regular 50-foot intervals with two intermediate locations, at 4+80 and 6+35. Intermediate readings are taken at unusually high or low spots, or in this case at the end of the leveling course.

Contour Mapping

Contour mapping is a valuable tool to identify land drainage patterns in order to plan cropping systems, reduce soil and moisture losses and increase crop production. Contour maps are also used in landscape and building layout planning.

Contour Defined:

A contour is an imaginary line connecting points having the same elevation. The shore line of a body of water is perhaps the best visible example of a contour.

Contour Interval:

A contour interval is the vertical distance, or difference in elevation, between two adjacent contours (Figure 4-6).

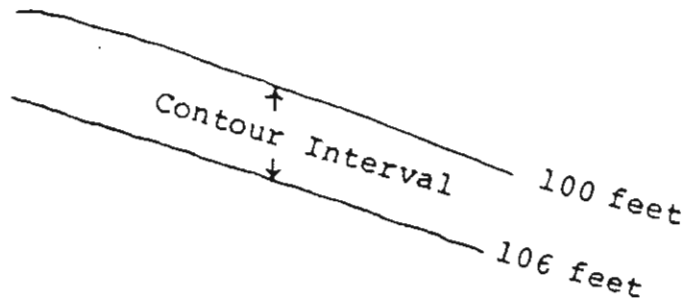
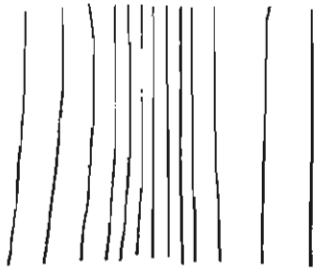

Fig. 4-6. An illustration of two contour lines having a contour interval of 6 feet.

Contour Lines:

A contour line on a map is used to describe and represent a ground surface having the same elevation. Contour lines on a map or plot which are spaced closely together represent a surface having a steep slope. If the lines are spaced further apart, they represent a more gentle slope assuming the same measurement scale is used. (Figure 4-7 and 4-8)



As seen on a map
Contour Lines

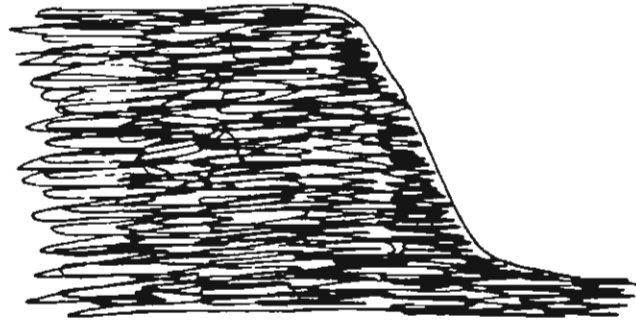

As seen on the ground
Slope

Fig. 4-7. Contour lines close together represent a steep slope.

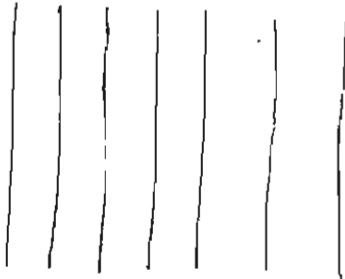

As seen on a map
Contour Lines

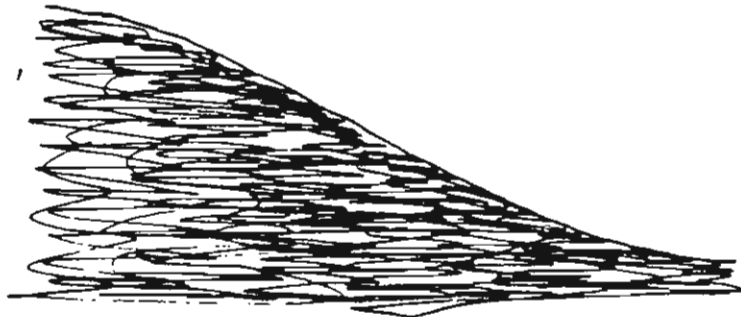

As seen on the ground
Slope

Fig. 4-8. Contour lines spaced well apart represent a gentle slope.

If the ground surface is rough and uneven, the contour lines will illustrate this irregularity on the map; if the ground surface is even, as on earthwork slopes, the contour lines will be uniform and parallel. (Figure 4-9)

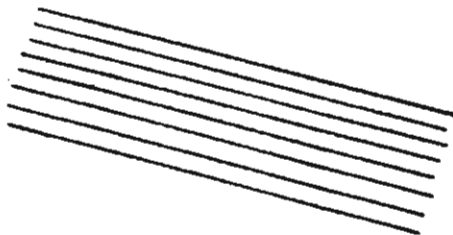

Smooth and Parallel

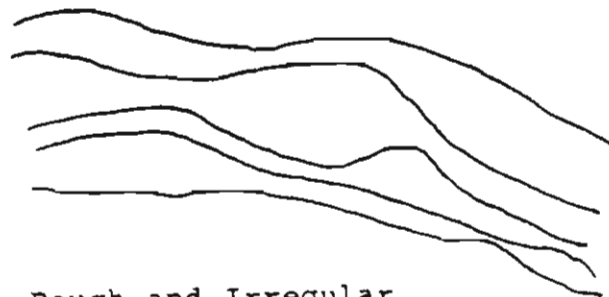

Rough and Irregular

Fig. 4-9

Contour Mapping:

Contour mapping can be accomplished using a basic and widely used system. It involves establishing a grid of squares, marked by a series of stakes on the ground surface. The elevation of the ground at each stake is determined so that contour lines may be drawn with reference to known elevations. (Figure 4-10)

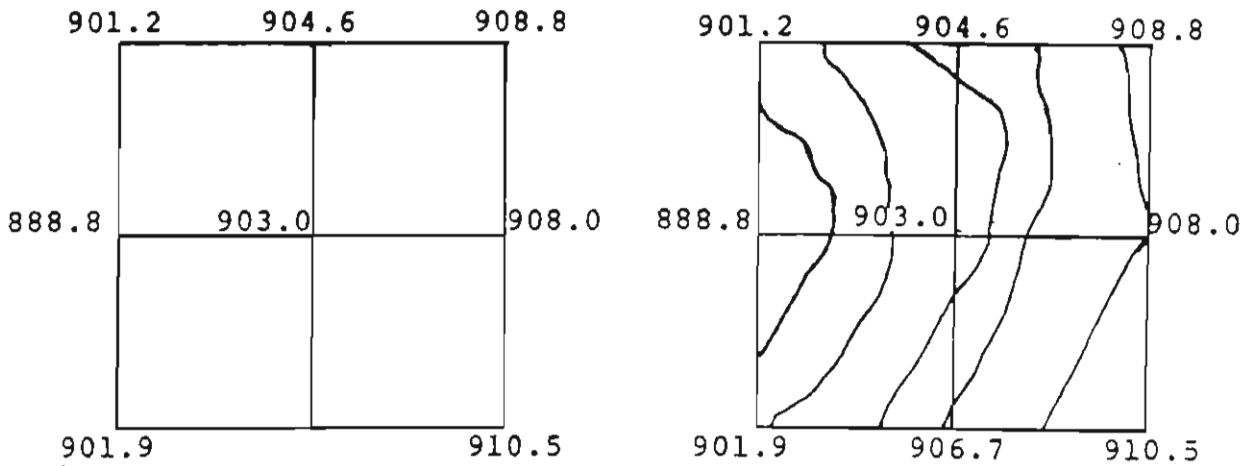

System of squares with deviations of the corner.

Contour lines drawn in.

Fig. 4-10

Mapping Procedure:

The mapping procedure for developing a contour map is as follows:

- Step I. The land area to be mapped should be laid out in a grid pattern. Establish an east-west line and a north-south baseline as near as possible to two boundaries of the field or area to be contour mapped. (Figure 4-11)

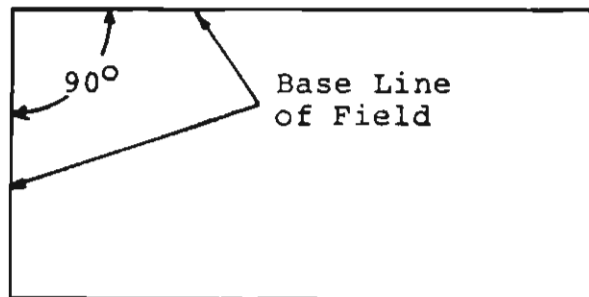

Fig. 4-11. Establishing baselines.

Step II. Starting from the corner where the two base lines meet, measure with a steel tape at 100 foot intervals along the base lines. Drive tall stakes into the ground at each 100 foot interval. These intervals should be marked as shown in Figure 4-12.

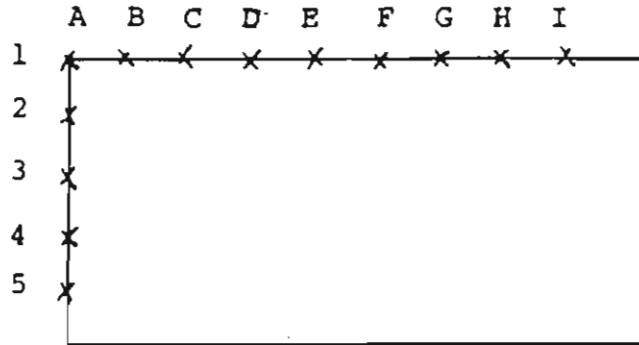

Fig. 4-12. Marking 100 foot intervals along each baseline.

Step III. Another line of stakes should be driven one grid interval distance (100 feet) from each baseline (Figure 4-13). From these points it is possible for the rodman to "sight-in" his position from any point by aligning the appropriate pair of stakes. (Figure 4-14)

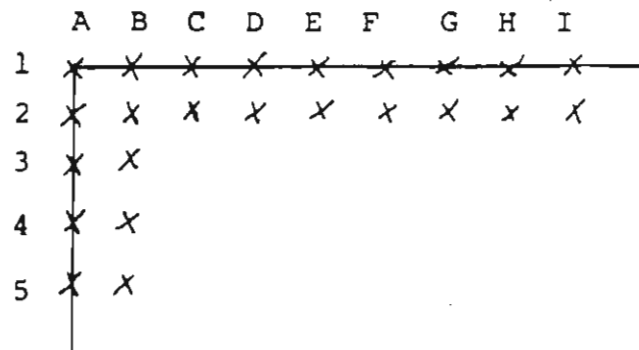

Fig. 4-13

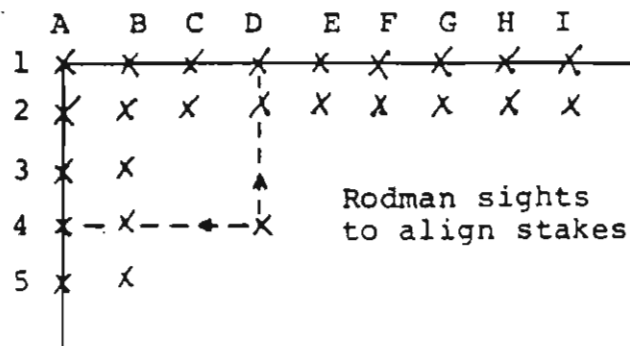

Fig. 4-14

Step IV. Set up the leveling instrument somewhere in the field where the entire field can be seen through the telescope tube.

Step V. Take a backsight on a bench mark, some other point of known elevation, or a sight on a permanent object which is then given an arbitrary elevation of 100.0 feet. (Figure 4-15)

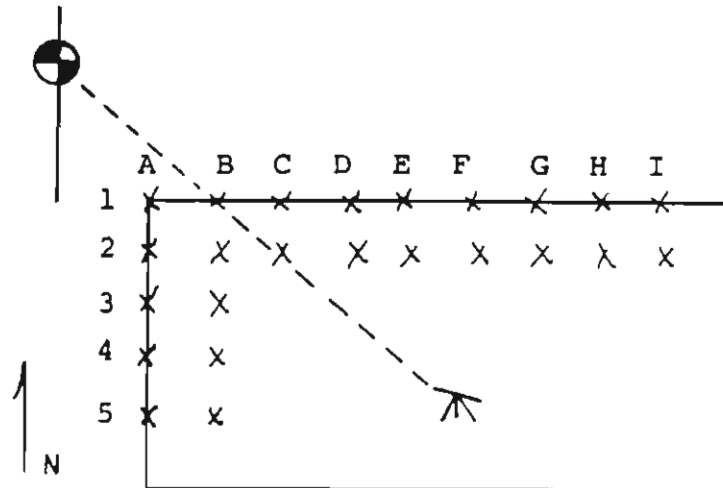

Fig. 4-15. Taking a Backsight.

Step VI. With a grid system located on the ground, the elevations of the various points are determined by profile leveling. Points are identified in the field notes by lettering each grid point on the east-west base line and numbering each grid point on the north-south base line. Each grid point then is identified by a combination of one letter and one number that corresponds to its location on the map. (Figure 4-16 and 4-17)

Step VII. To draw the contour map, reproduce the grids on ten square graph paper. The scale should conform to one of those found on an engineer's scale. Show the elevation of each grid point on the map. Contour lines are usually given values in even numbers. They will therefore seldom pass directly through a grid point of observed elevation. The location of the contour lines is determined by interpolation between adjacent grid points. (Figure 4-18)

Examples of Field Notes For Grid System

STATION	BACKSIGHT	INSTRUMENT HEIGHT	FORESIGHT	ELEVATION	REMARKS
BM	1.00	101.0		100.0	Pipe NW corner
A-1		101.0	4.5	96.5	
A-2			3.7	97.3	
A-3			3.2	97.8	
B-1			5.0	95.0	
B-2			4.2	95.8	
B-3			3.0	97.0	
C-1			7.0	93.0	
C-2			5.5	94.5	
C-3			3.9	96.1	
D-1			4.6	95.4	
D-2			5.8	94.2	
D-3			2.8	97.2	

Fig. 4-16

	A	B	C	D
1	96.5	95.0	93.0	95.4
2	97.3	95.8	94.5	94.2
3	97.8	97.0	96.1	97.2

Fig. 4-17

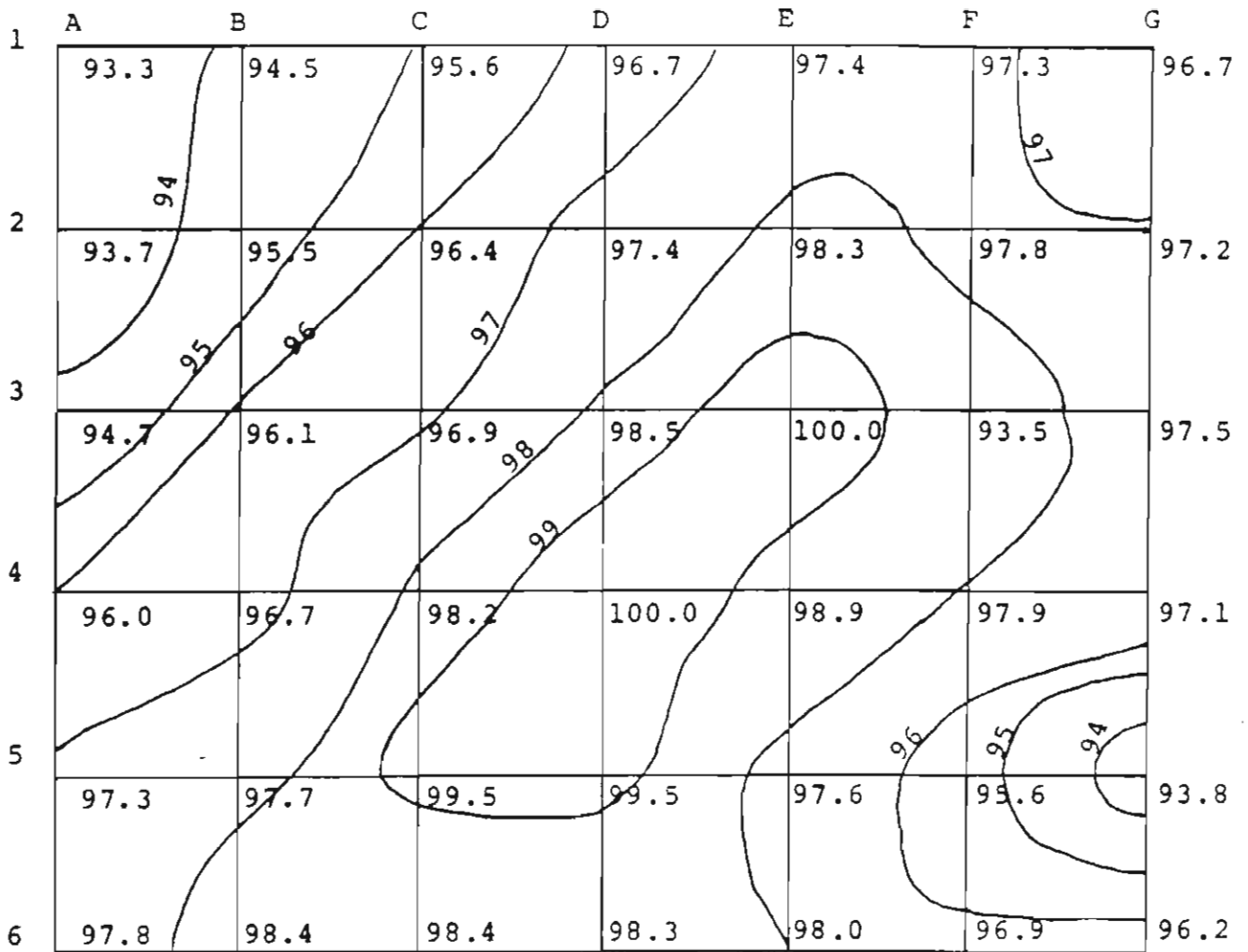

Fig. 4-18. Drawing in the contour lines.

Grades, Cuts and Fills

Land leveling operations require the use of soil moving machinery to remove material from points of high elevation and deposit it in low spots. The operation is called "cut and fill". Generally this operation is performed so that the completed land area is constructed to a specific degree of slope or grade for drainage or movement of water across a field at a desired rate.

Grades:

Grade is defined as the ascending or descending land surface compared to a level line of sight. It is commonly referred to as the slope of the ground. For example, if a field rises 1 foot in 100 feet the grade equals 1/100 or 1 percent. If the parcel of land should descend or drop 1 foot in 100 feet the slope or grade is still 1 percent,

but is a negative slope. Slope can also be expressed foot per foot instead of percent. For example, a slope of .001 ft/ft would indicate one foot fall in 1000 feet.

Cuts and Fills:

The vertical depth of soil that must be removed or added to make the ground surface conform to a prescribed grade or slope is referred to as cut or fill. For example, if the elevation of a field is 10 feet at a prescribed location and the land grading plan calls for an elevation of 8.5 feet at that point, a cut of 1.5 feet is required. Conversely if the elevation of the field at the point is 6.0 feet and the land grading plan calls for 8.5 feet elevation, a fill of 2.5 feet is required. Figure 4-19 shows a profile with cuts and fills.

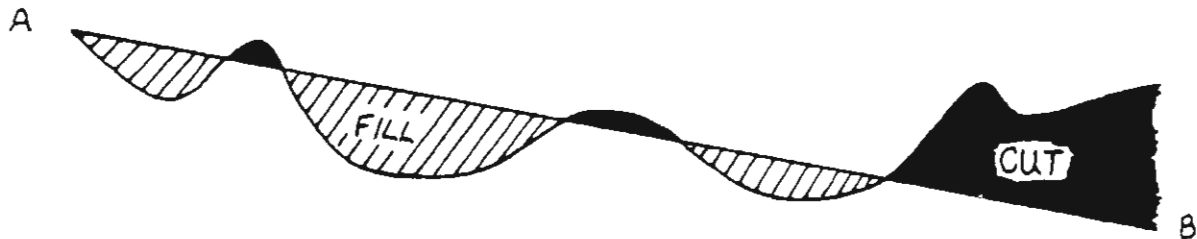

Fig. 4-19. Line AB represents the desired grade or slope of the parcel of land. Any portion of the contour line above the grade line AB is a cut; any portion of the contour line below the grade line AB is a fill. Earth must be removed from the cuts and placed in the fills to make the field level or meet the desired slope or grade.

If a parcel of land is improperly graded or an error is made in the calculation of a cut or fill, the grade or slope of the field may not be uniform. If the field is furrow irrigated, this uneven grade of slope may cause a backup of water in low areas. (Figure 4-20) When water stands in low areas for some period of time, the possibility of soil compaction, leaching of soil nutrients and lower crop production in that area of the field is increased.

A field that is properly leveled or graded will have a uniform distribution of water when irrigated. (Figure 4-21)

Grading Procedure:

1. Clear the field of all vegetation.



Fig. 4-20. Low area in field caused by improper grading or an error in the calculation of a cut or fill.

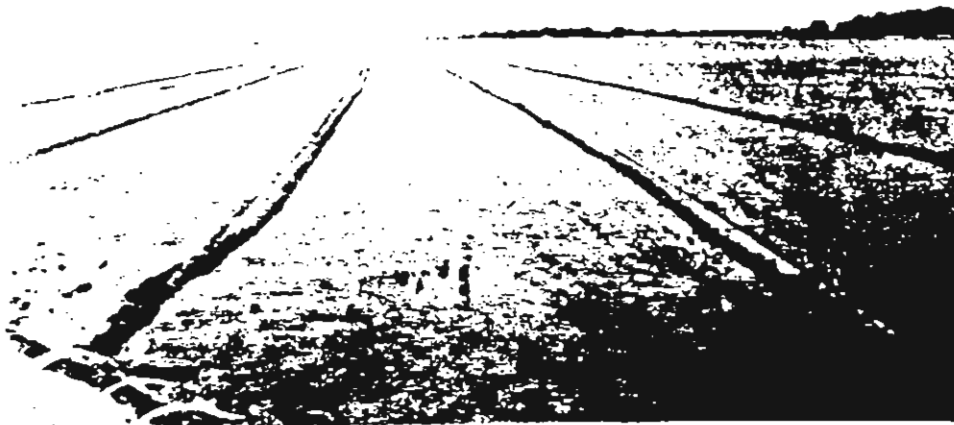
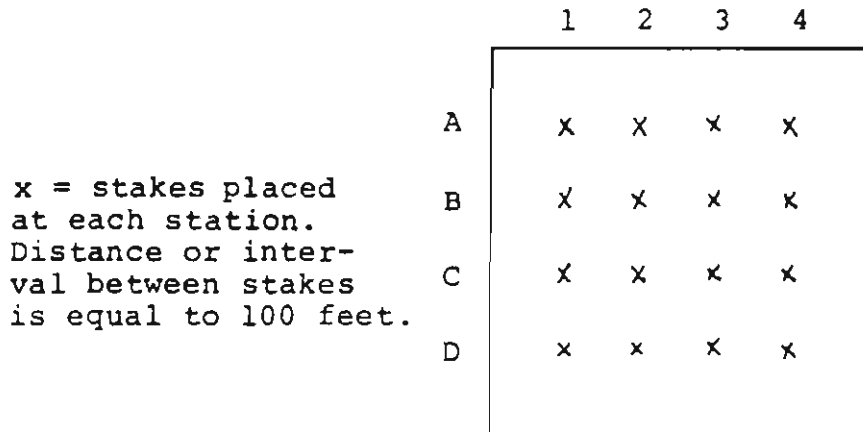

Fig. 4-21. A bordered field showing even distribution of water when the grading job is well done.

- Lay out a contour development grid on the field. The usual grid spacing is 100 feet in each direction; a 50 x 50 foot spacing can be used but it requires four times as many stakes to set, shoot, plot, compute and mark.



- Determine the ground elevation of each station (stake). Set up the leveling instrument where the entire field can be seen through the telescope tube. A backsight is taken on a bench mark or some other point of known elevation. If there is no point of known elevation, take a sighting on a permanent object and give it an arbitrary elevation of 100.0 feet.
- Once the rod readings are taken the elevation of each station must be determined. This is done by subtracting the rod reading from the height of instrument. For example, the elevation of station A-1 is computed as follows:

$$\frac{HI}{9.9} - \frac{Rod\ Reading}{3.5} = \frac{Elevation}{6.4\ feet}$$

6.4 is entered on the field map as shown in Figure 4-23. The other ground elevations are determined in a similar manner.

- It has been determined that the method of irrigating the field will be the furrow type. The National Engineering Handbook on irrigation states that the field should have a slope of between .27% and .4%. It is decided that a slope of .4% (a drop of .4 feet for every 100 feet of field) will be used.

6. The next step is to calculate the average elevation of the field. This is done by summing all the elevations and dividing by the number of elevations. In this case the average elevation is equal to:

$$\frac{90}{16} = 5.6 \text{ feet}$$

This average elevation is placed in the center of the map as in Figure 4-23.

7. The grade elevation of each station is now calculated. The interval between stations is 100 feet. The distance from the center station to station B2 is 50 feet north and 50 feet west. We therefore add .2 to the 5.6 elevation of the center station to determine the grade elevation of station B2 ($5.6 + .2 = 5.8$). The slope is .4 feet per 100 feet but since we are concerned with a distance of 50 feet to station B2 the slope will be half that for 100 feet or .2 feet.

For stations west of the center, the slope per 100 feet will be added to the elevation of the previous station, and subtracted for those east of the center.

8. Now that the grades at each station have been found, the cuts and fills can be determined. This is done by subtracting the grade and elevation at each station. If the elevation is larger than the grade, the value will be positive or will be a cut. If the elevation is smaller than the grade, the value will be negative and will be a fill. At station B4 for example, the present elevation is 5.4 feet. The desired elevation is 5.8 feet. Consequently a fill of .4 feet is needed at this station. At station A3, the present elevation is 6.5 feet and the desired elevation is 6.2 feet. A cut of .3 feet is necessary. Some stations, such as C2 are at grade and require no cut or fill.
9. The rod reading, elevation, grade elevation, and cut or fill taken at each station is marked on the upper face of each stake as shown in Figure 4-22. These same readings are entered on the surveying map as illustrated in Figure 4-23.
10. It is necessary to have a balance between cut and fill so that for a particular field, the cuts will be enough to fill the stations that are low. Normally an excess of cut over fill in a ratio of approximately 1.2 to 1.6 is allowed because of compaction of the fill and equipment operator errors in fully cutting all areas down to the desired grade.

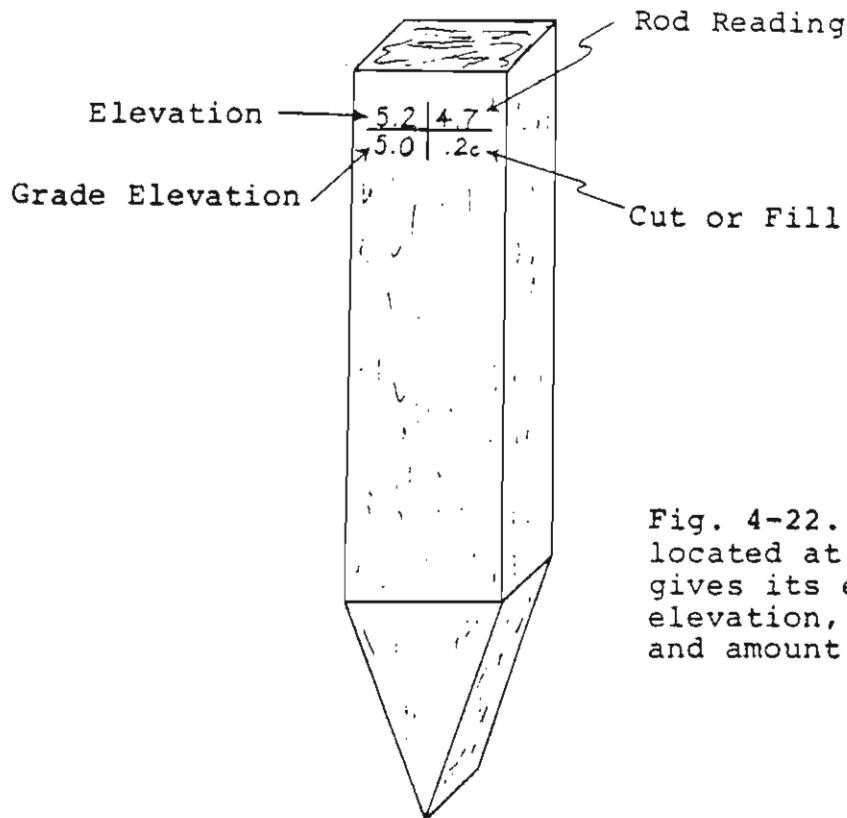

Fig. 4-22. Field stakes located at each station gives its elevation, grade elevation, rod reading, and amount of cut or fill.

To check this ratio, the cuts and fills are summed. In this case the cuts = .2 + .2 + .3 + .1 + .2 + .1 + .1 + .2 + .2 = 1.6.

The fills = .4 + .1 + .4 + .3 = 1.2

The cut/fill ratio is determined by the following formula:

$$\frac{\text{Sum of cuts}}{\text{Sum of fills}} = \text{cut/fill ratio}$$

For the field in Figure 4-22 the ratio is:

$$\frac{1.6}{1.2} = 1.33$$

Since 1.3 is within the range 1.2 - 1.6 there will be enough earth from the cuts to fill the lower areas of the field.

If a satisfactory ratio was not calculated, all grade elevations would have to be lowered by .1 and cuts and fills recalculated.

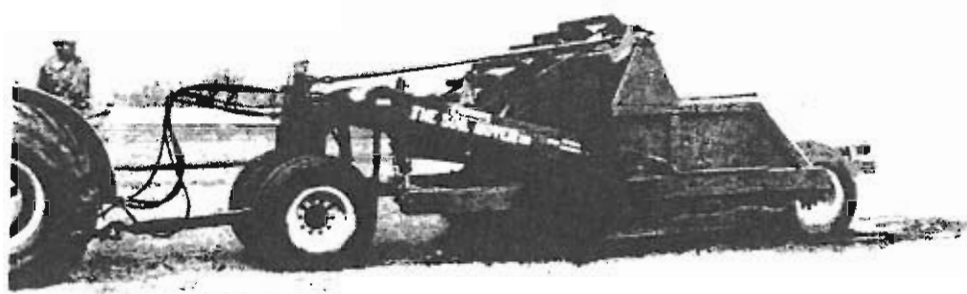

Fig. 4-24. Carryalls are commonly used in agricultural land leveling operations.

(Courtesy of the Farmhand Company)



Fig. 4-25. Land planing with a bottomless scraper

unloading. It is not possible to finish land surfaces to the exact grade with the carryall unless very skilled equipment operators are employed.

A bottomless scraper with a long frame is designed to provide a level land surface. It is manufactured in lengths up to 80 feet and widths up to 15 feet. The blade is attached

APPENDIX A

LAYING A FOUNDATION

Introduction:

There is more to constructing a good foundation than knowing the correct footing size and selecting a suitable wall material. The building must be laid out, the excavation dug, the drainage tile installed and the foundation walls waterproofed. This operation describes how to lay out a building foundation using the tripod level.

Procedure:

- Step I The first step in laying out a building foundation is to clear the site. This involves the removal of sod and tree stumps from the immediate area. Vegetation will harbor termites and should not be used for fill or left under the building.
- Step II Establish minimum grade of foundation. The ground on which the foundation is to be placed should be graded to provide drainage without excessive slope.
- Step III Locate the property corner stakes.
1. Drive a stake into the ground at one corner of the intended foundation (Stake A). If the ground is sloping, place the stake at the highest elevation. If the ground area is near level, any of the four corners will do as a starting point.
 2. Measure off the correct distance along one side of the foundation and place a second stake at that point (Stake B), on a line which parallels established buildings, fences and/or roads. Locate the center of the tops of the stakes by drawing 2 diagonal lines across the top. Where these diagonal lines intersect is the center of the stake; a nail is then driven part way into the center of the stake.

3. Attach builder's line to the nails in the stake tops. (Figure A-1)



Fig. A-1

4. Position the level directly over Stake A using the plumb bob and sight to Stake B. (Figure A-2)

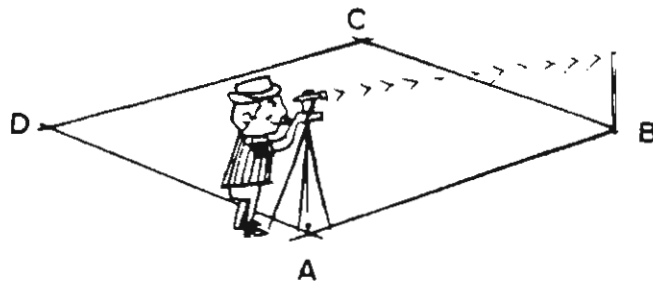
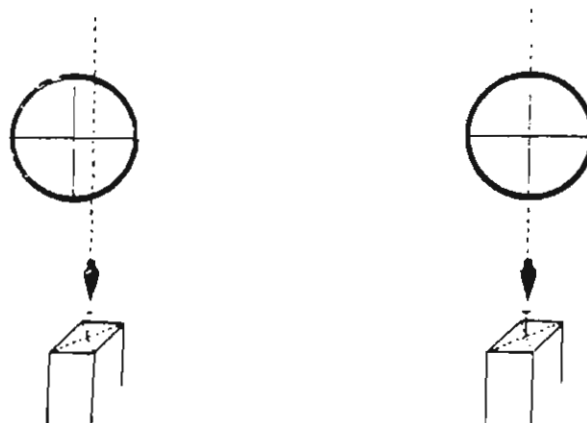

Fig. A-2

Hold the plumb bob over the nail in Stake B and align the vertical cross hair of the level with the plumb bob string. (Figure A-3)



- | | |
|---|---|
| <p>A. Cross hair & plumb bob string out of alignment.</p> | <p>B. Cross hair & plumb bob string in alignment.</p> |
|---|---|

Fig. A-3. Aligning the vertical cross hair of the farm level with the plumb bob.

5. When the vertical cross hair of the level is in line with the plumb bob, set the azimuth of the level to 0 degrees.
6. Turn the telescope tube exactly 90 degrees to the left and sight. (Figure A-4) Measure off the correct length of the foundation. Use the plumb bob, aligned with the vertical cross hair to locate Stake D. (Figure A-3) Drive a stake at that position. Locate the center of the stake top and drive a nail into the top at this point. When a line is connected between Stake A and B the outside edge of the foundation will be located. Connect Stake A with Stake D with a builder's line.

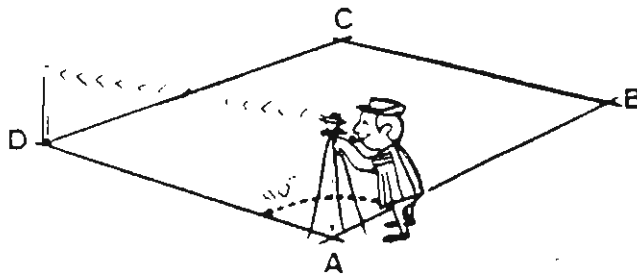

Fig. A-4

7. To determine the location of the fourth corner "C" you will need to measure the distance from Stake B to D. (Figure A-5) Measure the correct length and width of the foundation from Stake B to Stake C, from Stake D to Stake C, and from Stake A to C. Where all three points meet is the location of the fourth corner. (Figure A-6) Place Stake C at this point. Drive a nail in the center of the stake top. Connect a builder's line to the nail in the center of Stake C.

Step IV

Right angle batter boards must now be placed on all four corners of the foundation. The batter boards are approximately 6 to 8 feet from the corner stakes and parallel with the foundation walls. (Figure A-7) Right angle batter boards are made by nailing two 1" x 6" to three 2" x 4" stakes. (Figure A-8) The first batter board may be set at any convenient

level usually 6" above the surface of the ground and the other three batter board corners made level with it.

Fig. A-5

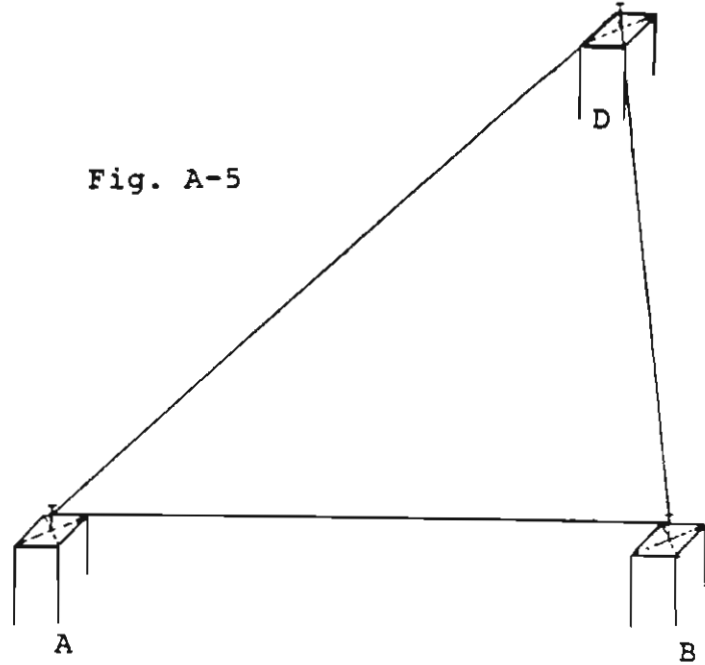
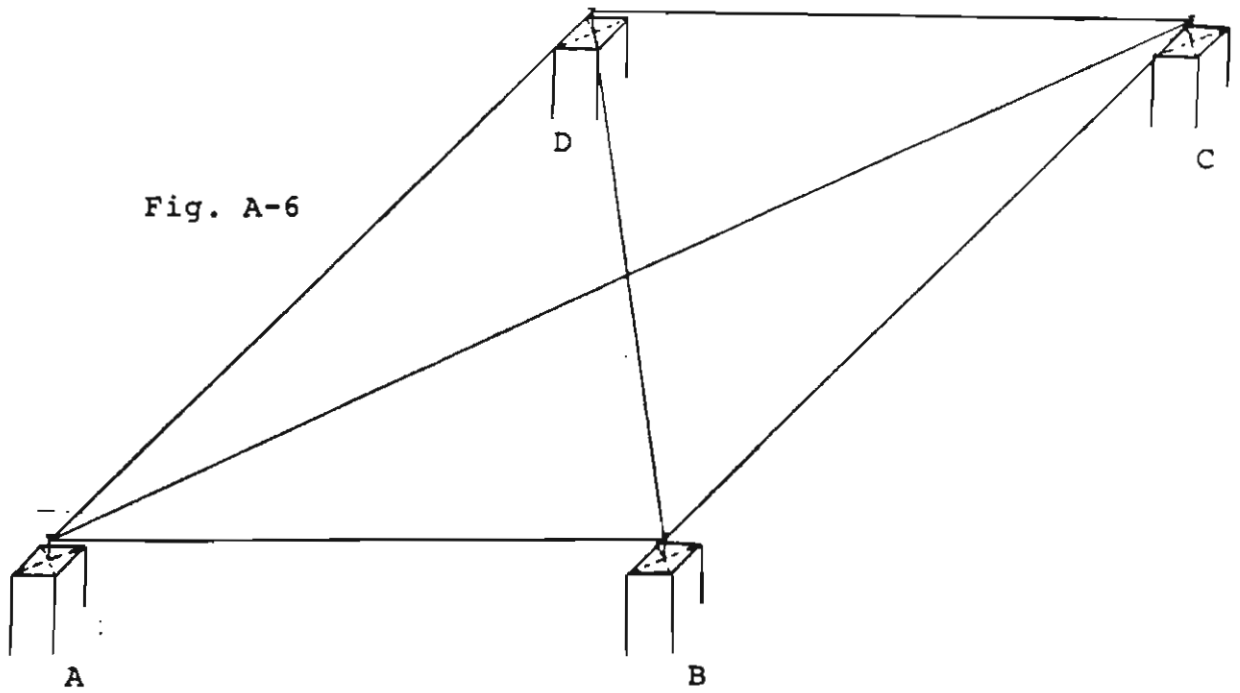

Fig. A-6



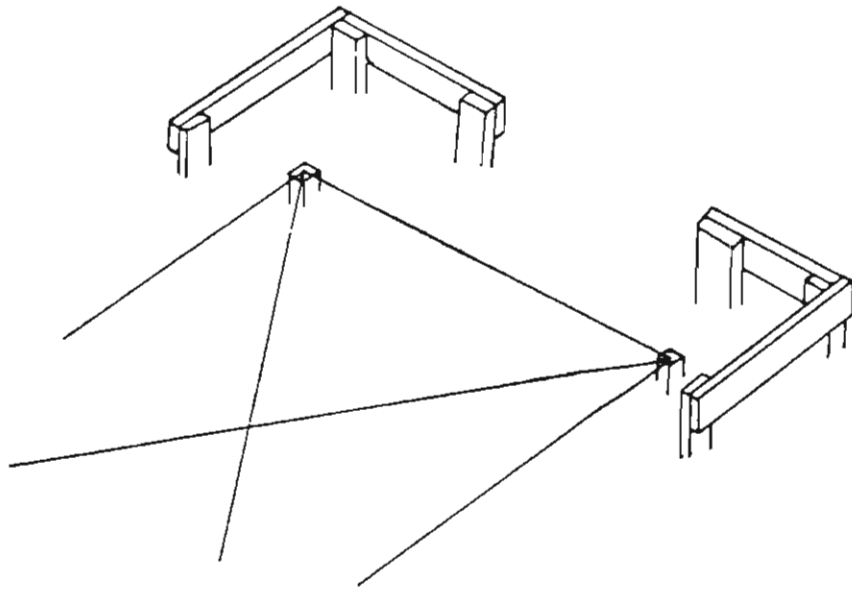

Fig. A-7

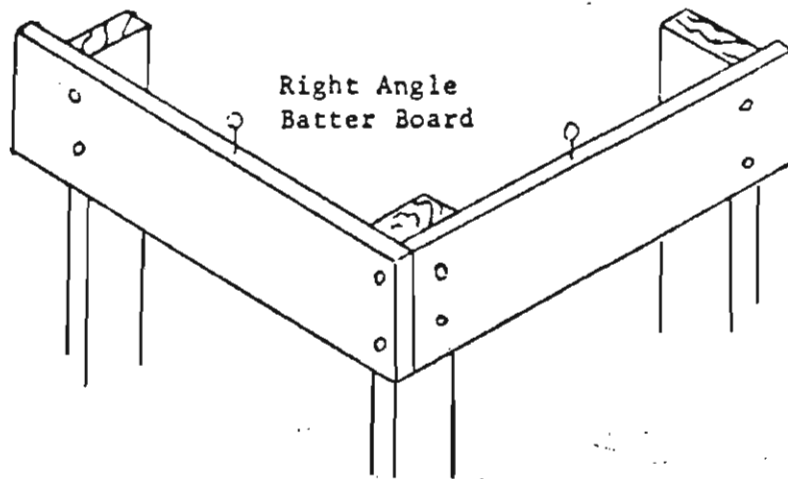

Fig. A-8

The steps to follow in setting the batter boards at the correct elevation are as follows. Assuming that the ground is fairly level, we set up the tripod level in the center of the proposed building area, and locate the position of the batter boards at corner A. A good way to do this is to fasten the batter boards to the stakes at a point slightly higher than the derived elevation and then drive the stakes carefully into the ground to bring the top of

the batter boards to the proper height and make them exactly level. This can be determined by taking rod readings on several points on the batter boards as the stakes are being driven. (Figure A-9) The batter boards may be set at the other three corners and leveled in the same manner and to the same elevation as corner A.

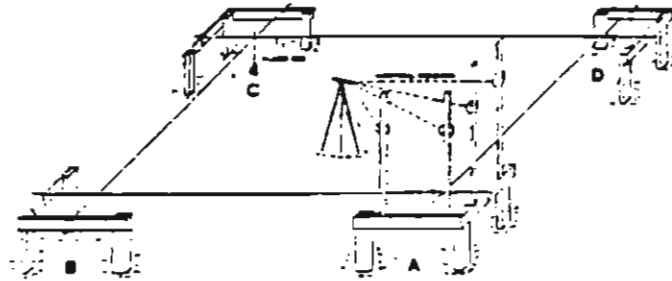

Fig. A-9

Step V. Tie strings on the batter boards to intersect directly over the four corners. Use a plumb bob to locate the intersections of the strings directly above the x marks on the tops of the corner stakes. You may find it useful to mark points of attachment of the strings to the batter boards by making a light saw cut or driving a nail into the batter board. You will then be able to take the string down and put them up again in the correct location after the corner stakes have been removed as the foundation trenches are dug. (Figure A-10).

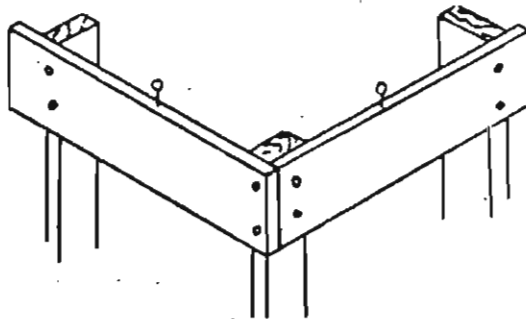

Fig. A-10

APPENDIX B

Field Note Page

A large grid of 20 columns and 25 rows, with a horizontal line across the middle. The grid is divided into two sections of 12.5 rows each. The top section has a vertical line after the 5th column, and the bottom section has a vertical line after the 10th column.

A grid of 20 columns and 10 rows.

APPENDIX C

HAND LEVEL

The hand level, Figure C-1, is used in agricultural leveling for approximate work only.

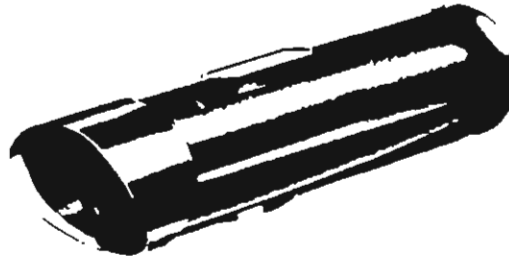

Fig. C-1. Hand Level.
Pocket size precision instruments for on-the-job checking and preliminary leveling.

The simplest form of a hand level has no telescope, but is simply a metal tube equipped with a bubble vial, a cross hair at one end, a peep-hole at the other end, and a small mirror inside and in the middle of the metal tube. Figure C-2 shows a cut-away view of a hand level.

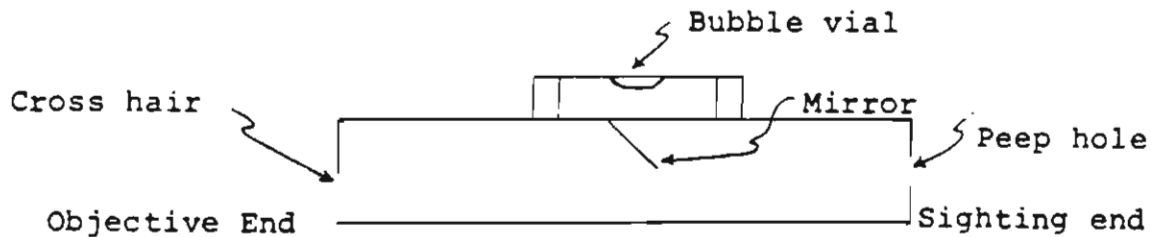

Fig. C-2. Cut-away view of a typical hand level.

The hand level is held in the hand and leveled by raising or lowering the objective end until the cross hair bisects the reflection of the bubble on the mirror. The object sighted and the reflection of the bubble are visible beside each other. (Figure C-3).



Fig. C-3. View through the hand level showing the appearance of the rod target when it has been placed at the same elevation as the instrument.

Owing to the unsteady support of the hand level, magnification is not helpful and therefore a telescope is seldom incorporated. The levelman can seldom read the rod therefore the target on the rod is used. The rodman adjusts the rod at the direction of the levelman and then reads its position.

APPENDIX D

THE METRIC SYSTEM

Measures of Length:

10 millimeters (mm.)	=	1 centimeter (cm.)
10 centimeters	=	1 decimeter (dm.)
10 decimeters	=	1 meter (m.)
1 meter	=	(39.37 inches (3.28083 feet (1.0936 yards
1 centimeter	=	.3937 inch
1 millimeter	=	(.03837 inch, or (approximately 1/25 inch.
1 kilometer	=	0.62137 mile
10 meters	=	1 dekameter (dm.)
10 dekameters	=	1 hektometer (hm.)
10 hektometers	=	1 kilometer (km.)
1 foot	=	.3048 meter
1 inch	=	(2.54 centimeters (25.4 millimeter

Measures of Surface:

1 square meter	=	(10.764 square feet (1.196 square yards
1 square centimeter	=	.155 square inch
1 square millimeter	=	.00155 square inch
1 square yard	=	.836 square meter
1 square foot	=	.0929 square meter
1 square inch	=	(6.452 square centimeters (645.2 square millimeters

STAKING OUT A FENCE

Introduction:

The instrument best suited for staking out a fence line or setting a series of stakes in line is the transit level. (Figure 2-3, Unit II) The telescope tube on this instrument can be swung in a vertical as well as a horizontal arc. The vertical cross hair is used for lining stakes, while the horizontal cross hair is used for leveling.

Procedure:

Frequently it is desirable to set a new fence line at right angles to an existing fence. To do this, the following procedure should be followed.

1. First set a stake approximately 3 feet from the old fence where the new fence is to begin. Set the transit level over the stake and on line with the new fence.
2. Measure the distance from the old fence to the stake. This distance in Figure E-1 is 3 feet.
3. Move along the old fence line about 20 feet and set a second stake 3 feet out from the old fence line. (Figure E-2) The two stakes are now parallel to the old fence.

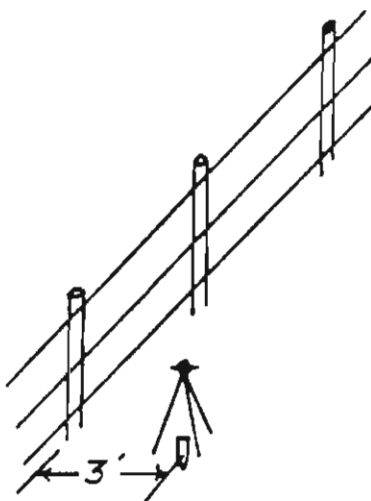

Fig. E-1

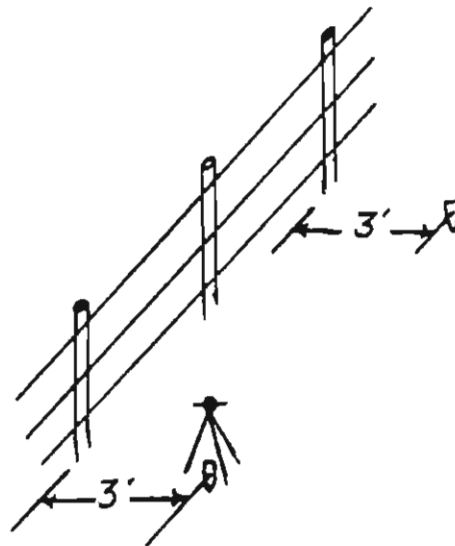
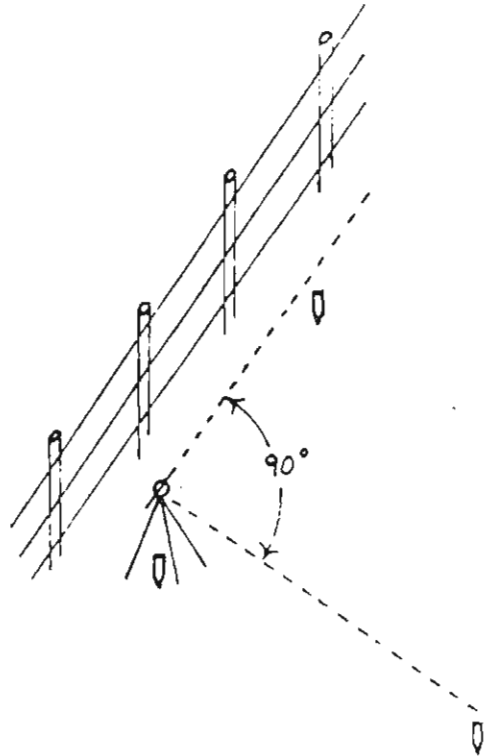

Fig. E-2

4. Turn the telescope tube and line it up so that the vertical cross hair bisects the second stake and set the azimuth on the horizontal graduated circle to 0° . Then turn the telescope until the indicator on horizontal graduated circle reads 90° pointing down the line of the proposed new fence. (Figure E-3)



5. Set a series of stakes to mark the location of the fence posts using a tape to measure the distances and the telescope to line them up. Tilt the telescope tube and focus it on each location, being careful not to move it away from the 90° setting.
6. After several stakes have been set and the distance becomes so great that the stakes cannot be sighted accurately it will be necessary to move the instrument. Move down the line to the last stake and set up the instrument directly over it so the plumb bob will exactly bisect the stake.
7. Take one sight backward and line the vertical cross hair up on a stake at any convenient distance back. Set the indicator to 0° and turn the telescope tube until it reads 180° . This procedure is continued until the fence has been completely staked out.

APPENDIX A

to the frame midway of its length at a height which is adjustable. It is mounted on swivel wheels to make it less unwieldy to turn. When in use the blade is permanently set at a level which will maintain about one-third of a load in the bowl. With this adjustment properly made the machine will, as it is drawn across a field, automatically remove high spots and fill depressions of a diameter equal to nearly one-half its length. Obviously the longest machine available will perform the best. It is customary to take care of the final finishing work with a machine of this type by scraping in three directions -- in each of the two diagonal directions and in the direction of irrigation. The operation is termed land planing.

After the first cropping practice settling will occur in fill areas of the field. Additional planing will be required to provide even water distribution. See Figure 4-20 and 4-21.

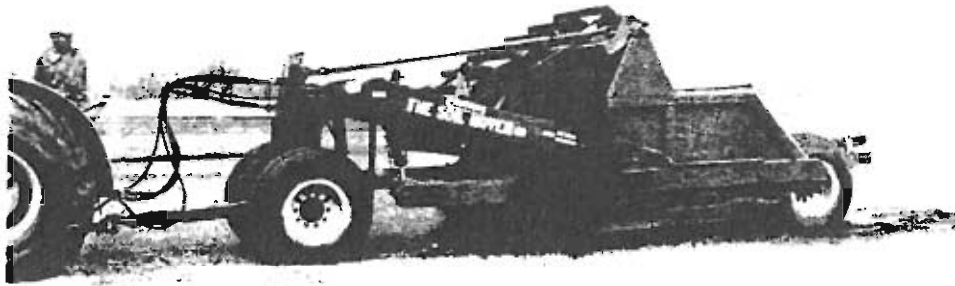

Fig. 4-24. Carryalls are commonly used in agricultural land leveling operations.

(Courtesy of the Farmhand Company)



Fig. 4-25. Land planing with a bottomless scraper

unloading. It is not possible to finish land surfaces to the exact grade with the carryall unless very skilled equipment operators are employed.

A bottomless scraper with a long frame is designed to provide a level land surface. It is manufactured in lengths up to 80 feet and widths up to 15 feet. The blade is attached